

FEATURES

- Solid bar-stock drilled design
- 3 different shank styles
- Threaded process connection

APPLICATION

- Air & flue gas
- Tanks & vessels
- Oil & Gas applications
- Corrosive environments
- Power & Steel industries
- HVAC, Air filters & utilities
- On-shore/Off-shore application

Bar-stock



STANDARD SPECIFICATIONS

Shank form	:	Straight
Material	:	AISI 316 SS
Instrument connection	:	1/2" NPT (F) / 1/2" BSP (F)
Bore diameter	:	6.6 mm
Lag extension	:	50 mm
Root diameter	:	21.0 mm
Tip diameter	:	21.0 mm
Immersion length	:	100 mm
Tip thickness	:	5 mm
Process connection	:	3/4" NPT (M) / 3/4" BSP (M)
Head type	:	Hex
Head size	:	27 mm

DIMENSIONAL DRAWING

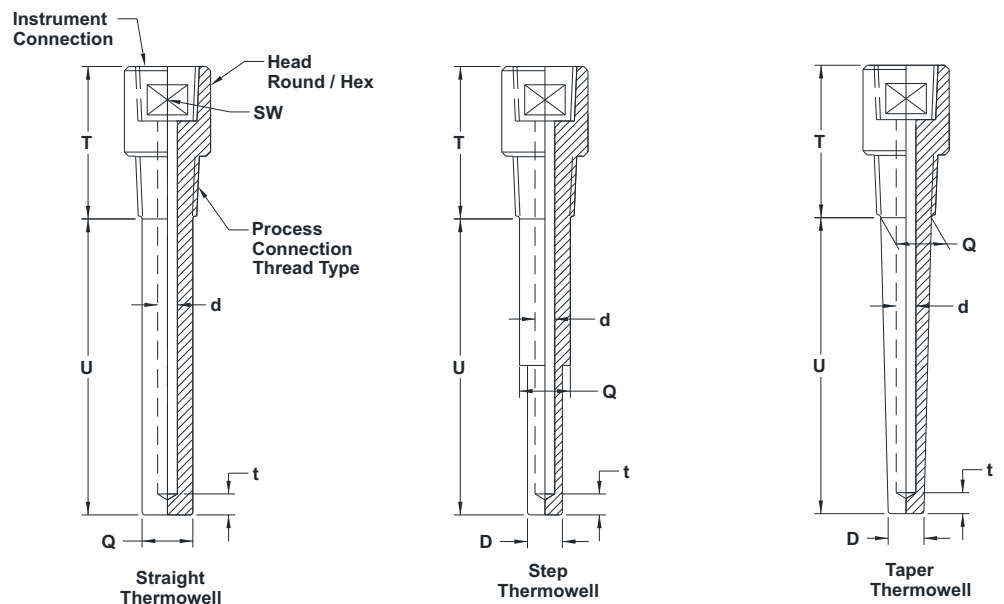

REFERENCE

ASME PTC 19.3TW:2010

ORDERING CODES

1. SHANK FORM

S	Straight	E	Stepped
T	Tapered		

S

2. MATERIAL

MB	Carbon Steel / ASTM A105		
MC	AISI 304SS	ME	AISI 310 SS
MF	AISI 316 SS	MG	AISI 316L SS
MM	Monel 400	MN	Monel K-500
MO	Hastelloy C-276	MQ	Inconel 600
MR	Inconel 625	MS	Inconel 800
MT	Inconel 825	MV	Titanium
MY	Alloy 20	M6	AISI 446 SS
MI	AISI 321 SS		

MB

3. INSTRUMENT CONNECTION

02N	1/4" NPT (F)	04N	1/2" NPT (F)
05N	3/4" NPT (F)	06N	1" NPT (F)
02B	1/4" BSP (F)	04B	1/2" BSP (F)
05B	3/4" BSP (F)	06B	1" BSP (F)
04M	M20 x 1.5 mm (F)		

02N

4. PROCESS CONNECTION

14N	1/2" NPT (M)	15N	3/4" NPT (M)
16N	1" NPT (M)	17N	1.5" NPT (M)
18N	2" NPT (M)	14B	1/2" BSP (M)
15B	3/4" BSP (M)	16B	1" BSP (M)
17B	1.5" BSP (M)	18B	2" BSP (M)
14M	M20 x 1.5 mm (M)		

14N

5. HEAD TYPE

H	Hex
L	Round with spanner slot

H

6. HEAD SIZE

XX	Mention in 'mm'
-----------	-----------------

27

7. LAG EXTENSION ("T")

XXX	35 mm up to 250 mm
------------	--------------------

50

8. ROOT DIAMETER ("D")

XX.X	Mention in 'mm'
-------------	-----------------

21

9. TIP DIAMETER ("D")

XX.X	Mention in 'mm'
-------------	-----------------

21

10. BORE DIAMETER ("d")

A	6.6 mm	C	9.0 mm
D	9.6 mm	F	11 mm
G	13 mm		

A

11. IMMERSION LENGTH ("U")

XXXX	50 mm up to 1000 mm
-------------	---------------------

100

12. STEP STYLE

S	Straight
T	Taper

X

13. STEP / TAPER LENGTH ("S")

XXX	Mention in 'mm'
------------	-----------------

XXX

14. TIP THICKNESS ("t")

M	5 mm	N	6.35 mm (1/4")
O	10 mm		

M

15. OTHER OPTIONS

XI	Plug & chain in SS
XK	Electro polishing
XL	Marking by laser
XM	Marking by engraving
TC	Material test certificate 3.1
TG	IGC test
TH	Hydro test certificate
TI	IBR certification
TM	Material test certificate 2.2
TN	Tested to NACE standards
TW	WFC as per PTC 19.3TW:2010
TS	Radiography for bore concentricity
TU	Ultrasonic test

XM

Ordering Example : W102-S-MB-02N-14N-H-27-50-21-21-A-100-M-XM

NOTES:

1. Other pipe/tube sizes, "U" lengths, connections are available. please contact factory for details.
2. Please refer "Technical Guidance Sheet" for the proper selection of connections according to Head size and Outer diameter of the well.