

FEATURES

- All SS measuring system
- Socket-case, direct welded
- Low pressure application (<0.6 bar)
- Zero adjustment on dial

APPLICATION

- Liquid & gaseous mediums
- Corrosive environments
- Oil & Gas applications
- Chemical & Petrochemical
- Food & Beverages
- Nuclear power plants

Capsule



STANDARD PARAMETERS

Accuracy	:	CL 1.6
Ambient temperature	:	-40...+65°C
Service temperature	:	150°C max.
Pressure limits	:	Steady pressure up to FS value Fluctuating pressure up to 90% of FS value
Weld joint	:	TIG argon arc welding

MATERIAL OF CONSTRUCTION

Sensing element	:	Welded capsule
Case & Ring material	:	AISI 304 SS (Bayonet type)
Capsule	:	AISI 316 SS
Shank	:	AISI 316L SS (Welded directly to case)
Movement mechanism	:	AISI 304 SS
Dial	:	Aluminum, black graduation on white background with external zero adjustment on dial
Pointer	:	Fixed, aluminum, black powder coated
Gaskets, Blow off disc & filling plug	:	Neoprene
Window	:	Sheet glass

STANDARD SPECIFICATIONS

Dial size	:	DN63 / DN100 / DN125 / DN150
Range	:	-600...25...600 mbar 6...16 mbar (available in DN 150) 100...600 mbar (available in liquid dampening)
Mounting pattern	:	Direct, Bottom connection
Process connection	:	1/2" NPT (M)
Ingress protection	:	IP 54
Execution	:	Dry

TEMPERATURE EFFECT

When temperature of the measuring system deviates from reference temperature (+20°C) max error $\pm 0.4\%$ / 10K of true scale value.

REFERENCE

EN 837-3

DIMENSIONAL DRAWING

Type B0

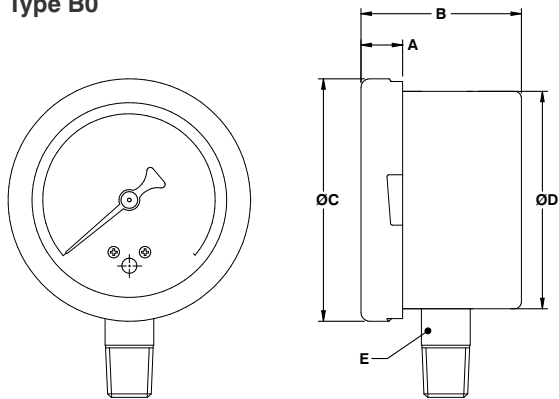

DN	A	B	ØC	ØD	E	Weight (grams)
63	12	43	70	62.5	SQ.14	230

Type B0

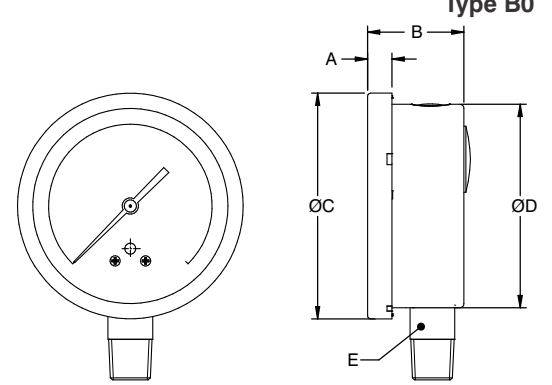

DN	A	B	ØC	ØD	E	Weight (grams)
100	12	48	111	100	SQ.22	523
125	15	48	129	118.5	SQ.22	714
150	15	48	161	149	SQ.22	932

Type B1

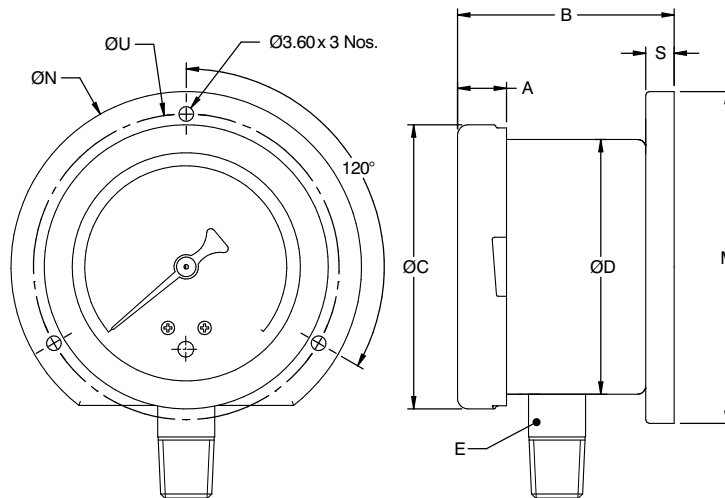

DN	A	B	ØC	ØD	E	ØN	ØU	M	S	Weight (grams)
63	12	42	70	62.5	SQ.14	86	75	77	7	284

Type B1

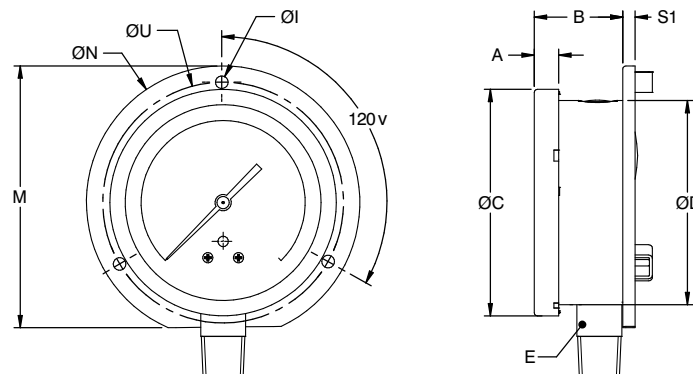

DN	A	B	ØC	ØD	E	ØI	M	ØN	S1	ØU	Weight (grams)
100	12	52	111	100	SQ.22	6	128	134	6	118	638
125	15	50	129	118.5	SQ.22	6	143.5	150	4	137	821
150	15	52	161	149	SQ.22	6	172.4	186	6	168	1105

All dimensions are in mm.

DIMENSIONAL DRAWING

Type R0

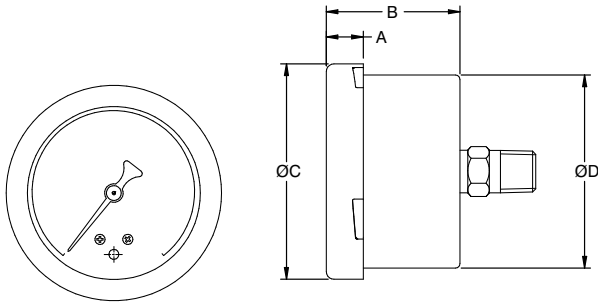

DN	A	B	ØC	ØD	Weight (grams)
63	12	43	69.7	62.5	230

Type R0

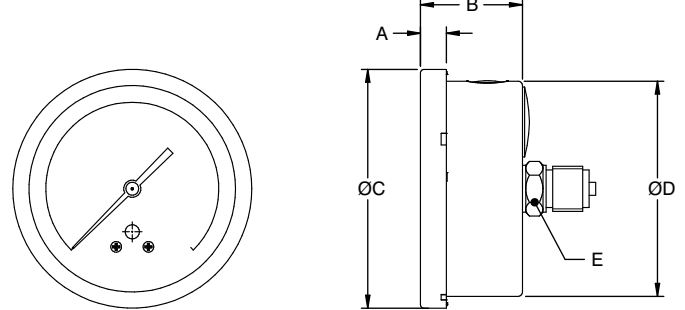

DN	A	B	ØC	ØD	E	Weight (grams)
100	12	48	111	100	SQ.22	520
125	15	48	129	118.5	SQ.22	710
150	15	48	161	149	SQ.22	925

Type R2

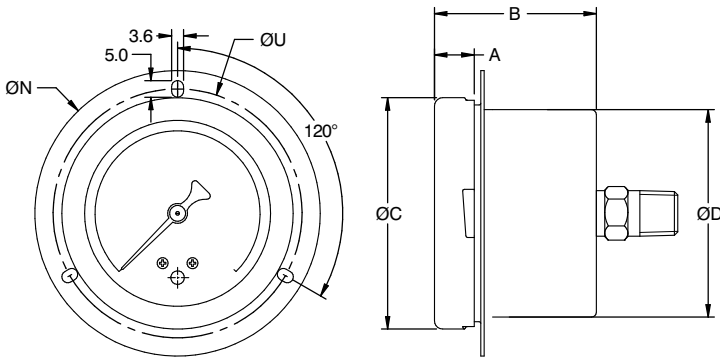

DN	A	B	ØC	ØD	ØN	ØU	Weight (grams)
63	12	43	69.7	62.5	86	75	240

Type L0

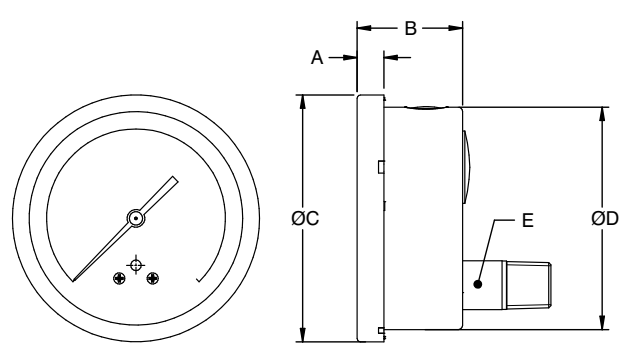

DN	A	B	ØC	ØD	E	Weight (grams)
100	12	48	111	100	SQ.22	523
125	15	48	129	118.5	SQ.22	714
150	15	48	161	149	SQ.22	932

Type L1

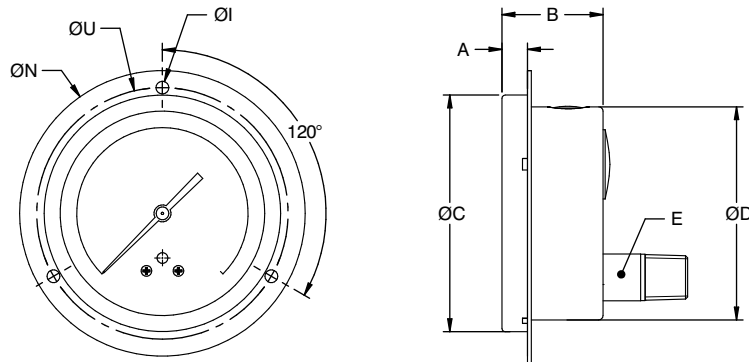

DN	A	B	ØC	ØD	E	ØI	ØN	ØU	Weight (grams)
100	12	48	111	100	SQ.22	6	134	118	605
125	15	48	129	118.5	SQ.22	6	150	137	814
150	15	48	161	149	SQ.22	6	186	168	2458

All dimensions are in mm.

DIMENSIONAL DRAWING

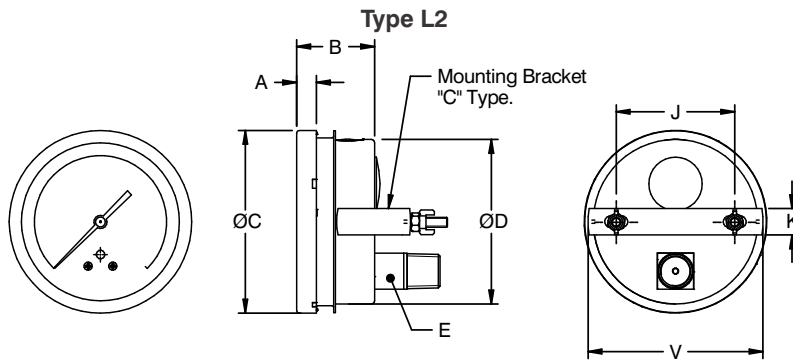

DN	A	B	ØC	ØD	E	J	K	V	Weight (grams)
100	12	48	111	100	SQ.22	72	16	108	620
125	15	48	129	118.5	SQ.22	75	15	125	815
150	15	48	161	149	SQ.22	106.5	16	158.5	1091

All dimensions are in mm.

ORDERING CODES

1. DIAL SIZE

25	63 mm / 2½"	04	100 mm / 4"
05	125 mm / 4½"	06	150 mm / 6"

2. RANGE

XXX Refer "Range Table"

3. MOUNTING PATTERN

B0	Direct, Bottom connection
B1	Wall/Surface/Projection mounting, Bottom connection
B2	2" Pipe/Yoke mounting, Bottom connection
B3	Panel/Front flange mounting, Bottom connection
R0	Centre, Back connection
R2	Panel/Front flange mounting, Centre back connection
L0	Lower, Back connection
L1	Panel/Front flange mounting, Lower Back connection
L2	Panel/bracket mounting, Lower Back connection

4. PROCESS CONNECTION

12B	¼" BSP (M)
12N	¼" NPT (M)
13B	3/8" BSP (M)
14B	½" BSP (M)
14M	M20 X 1.5 mm (M)
14N	½" NPT (M)

5. INGRESS PROTECTION

EV IP 54

6. EXECUTION

EA Dry

7. OTHER OPTIONS

BA	Case & Ring in AISI 316 SS (B0)
BB	Case & Ring in AISI 316 SS (B1)
BC	Case & Ring in AISI 316 SS (B2)
BD	Case & Ring in AISI 316 SS (B3)
BG	Case & Ring in AISI 316 SS (R0)
BI	Case & Ring in AISI 316 SS (R2)
BK	Case & Ring in AISI 316 SS (L0)
BL	Case & Ring in AISI 316 SS (L1)
BM	Case & Ring in AISI 316 SS (L2)
GB	Plexi glass
GC	Shatterproof safety glass
GL	AISI 316 SS movement
RW	Vent plug, ON-OFF type
TA	5 - point calibration certificate
TC	Material test certificate 3.1
TM	Material test certificate 2.2
TO	Certification for Oxygen service
XF	SS tag plate, AISI 304 SS
XG	SS tag plate, AISI 316 SS
XR	Custom designed dial
XT	Dial tag marking

Ordering Example : P601-04-XXX-B0-14N-ER-EA

NOTES

- For other connections, please contact factory.
- Case & Ring in AISI 316 SS from DN100 onwards.
- DN63 available in mounting pattern B0 and R0 only.
- DN63 available with ¼" connections. Other connections through adaptors.