

Lift Check Valve

ECOLINE-RA16

Operating Manual



Legal information

Operating Manual ECOLINE-RA16

All rights reserved. The contents provided herein must neither be distributed, copied, reproduced, edited or processed for any other purpose, nor otherwise transmitted, published or made available to a third party without the manufacturer's express written consent.

Subject to technical modification without prior notice.

KSB Italia SpA, Concorezzo 07/11/2017

Contents

	Glossary.....	5
1	General.....	6
	1.1 Principles.....	6
	1.2 Target group.....	6
	1.3 Other applicable documents.....	6
	1.4 Symbols.....	6
2	Safety.....	7
	2.1 Key to safety symbols/markings.....	7
	2.2 General.....	7
	2.3 Intended use.....	8
	2.4 Personnel qualification and training.....	8
	2.5 Consequences and risks caused by non-compliance with this manual.....	8
	2.6 Safetyawareness.....	8
	2.7 Safety information for the operator/user.....	9
	2.8 Safety information for maintenance, inspection and installation.....	9
	2.9 Unauthorised modes of operation.....	9
3	General safety regulations.....	10
4	Transport/Temporary Storage/Disposal.....	12
	4.1 Checking the condition upon delivery.....	12
	4.2 Transport.....	12
	4.3 Storage/preservation.....	12
	4.4 Return to supplier.....	12
	4.5 Disposal.....	13
5	Valve Description.....	14
	5.1 General description.....	14
	5.2 Marking.....	14
	5.3 Operating data.....	14
	5.4 Fluids handled.....	14
	5.5 Design details.....	15
	5.6 Pressure/temperature ratings.....	15
	5.7 Materials.....	15
	5.8 Function.....	16
	5.9 Scope of supply.....	16
	5.10 Dimensions and weights.....	16
6	Installation at Site.....	17
	6.1 General information/Safety regulations.....	17
	6.2 Installation.....	17
	6.3 Measuring computer.....	17
7	Commissioning/Start-up/Shutdown.....	18
	7.1 Commissioning/Start-up.....	18
	7.1.1 Prerequisites for commissioning/start-up.....	18
	7.1.2 Actuation.....	18
	7.2 Shutdown.....	18
	7.2.1 Measures to be taken for shutdown.....	18
8	Servicing/Maintenance.....	19
	8.1 Safety regulations.....	19
	8.2 Maintenance.....	19
9	Trouble-shooting.....	21
10	Volume Flow Rate Measurement.....	22
	10.1 Taking measurements.....	22

10.2 Basic trouble-shooting	22
Index	23

Glossary

Technical literature

Refer to the product catalogue for the technical literature on our products at www.ksb.it

1 General

1.1 Principles

This operating manual is supplied as an integral part of the type series and variants indicated on the front cover. The manual describes the proper and safe use of this equipment in all phases of operation.

In the event of damage, immediately contact the KSB sales organization responsible in order to maintain the right to claim under warranty.

1.2 Target group

This operating manual is aimed at the target group of trained and qualified specialist technical personnel.

1.3 Other applicable documents

Table 1: Overview of other applicable documents

Document	Contents
Type series booklet	Description of the valve
Flow characteristics ¹⁾	Information on Kv and zeta values
General assembly drawing ²⁾	Sectional drawing of the valve
Sub-supplier product literature ³⁾	Operating manuals and other product literature for the accessories

Observe the relevant manufacturer's product literature for the accessories.

1.4 Symbols

Table 2: Symbols used in this manual

Symbol	Description
✓	Conditions which need to be fulfilled before proceeding with the step-by-step instructions
▷	Safety instructions
⇄	Result of an action
⇄	Cross-references
1. 2.	Step-by-step instructions
	Note Recommendations and important information on how to handle the product

1) If any

2) If inclusion in the scope of supply has been agreed; otherwise refer to the type series booklet.

3) If inclusion in the scope of supply has been agreed.







2 Safety



All the information contained in this section refers to hazardous situations.

2.1 Key to safety symbols/markings

Table 3: Definition of safety symbols/markings

	DANGER This signal word indicates a high-risk hazard which, if not avoided, will result in death or serious injury.
	WARNING This signal word indicates a medium-risk hazard which, if not avoided, could result in death or serious injury.
	CAUTION This signal word indicates a hazard which, if not avoided, could result in damage to the machine and its functions.
	General hazard In conjunction with one of the signal words this symbol indicates a hazard which will or could result in death or serious injury.
	Electrical hazard In conjunction with one of the signal words this symbol indicates a hazard involving electrical voltage and identifies information about protection against electrical voltage.
	Machine damage In conjunction with the signal word CAUTION this symbol indicates a hazard for the machine and its functions.

2.2 General

This manual contains general installation, operating and maintenance instructions that must be observed to ensure safe valve operation and prevent personal injury and damage to property.

The safety information in all sections of this manual must be complied with.

The operating manual must be read and fully understood by the specialist personnel/operators responsible prior to installation and commissioning.

The contents of this operating manual must be available to the specialist personnel at the site at all times.

Instructions and information attached directly to the valve must always be complied with and kept in a perfectly legible condition at all times. This applies to, for example: flow direction arrow, manufacturer, type designation, nominal pressure, nominal size, year of construction and material.

The operator is responsible for ensuring compliance with all local regulations not taken into account in this operating manual.

The design, manufacture and testing of the valves are subject to a QM system to DIN EN ISO 9001. Compliance with these requirements, however, is based on normal, predominantly static loading.

Valves exposed to creep-rupture conditions have a limited service life and have to meet the applicable regulations stipulated in the technical codes.

In the case of customised special variants, further restrictions may apply with regard to the operating mode and service life. Please refer to the relevant sales literature for this information.

This operating manual does not take into account:

- Any eventualities or incidents which may occur during installation performed by the customer, operation and maintenance.
- Local regulations; the operator must ensure that such regulations are strictly observed by all, including the personnel called in for installation.

2.3 Intended use

- Only operate valves which are in perfect technical condition.
- Do not operate partially assembled valves.
- The valve must only be used for fluids specified in the product literature.
- Only operate the valve within the permissible operating range specified for pressure and temperature.
- The valve's design and rating are based on predominantly static loading in accordance with the codes applied. Consult the manufacturer if the valve is subjected to dynamic loads or any other additional influences.
- Consult the manufacturer about any other modes of operation not described in the product literature.

Prevention of foreseeable misuse

- Never exceed the permissible operating limits specified in the data sheet or product literature regarding pressure, temperature, etc.
- Observe all safety information and instructions in this operating manual.

2.4 Personnel qualification and training

All personnel involved must be fully qualified to transport, install, operate, maintain and inspect the product this manual refers to and be fully aware of the interaction between the valve and the system.

The responsibilities, competence and supervision of all personnel involved in transport, installation, operation, maintenance and inspection must be clearly defined by the operator.

Deficits in knowledge must be rectified by means of training and instruction provided by sufficiently trained specialist personnel. If required, the operator can commission the manufacturer/supplier to train the personnel.

Hands-on training at the valve must always be supervised by specialist technical personnel.

2.5 Consequences and risks caused by non-compliance with this manual

- Non-compliance with this operating manual will lead to forfeiture of warranty cover and of any and all rights to claims for damages.
- Non-compliance can, for example, have the following consequences:
 - Hazards to persons due to electrical, thermal, mechanical and chemical effects and explosions
 - Failure of important product functions
 - Failure of prescribed maintenance and servicing practices
 - Hazard to the environment due to leakage of hazardous substances

2.6 Safety awareness

In addition to the safety information contained in this manual and the intended use, the following safety regulations shall be complied with:

- Accident prevention, health and safety regulations
- Explosion protection regulations
- Safety regulations for handling hazardous substances
- Applicable standards, directives and laws

2.7 Safety information for the operator/user

Actuator-operated valves are intended for use in areas which cannot be accessed by unauthorised persons. Operation of these valves in areas which can be accessed by unauthorised persons is only permitted if appropriate protective devices are fitted at the site. This must be ensured by the operator.

- The operator shall fit contact guards for hot, cold and moving parts and check that the guards function properly.
- Do not remove any contact guards during operation.
- Provide the personnel with protective equipment and make sure it is used.
- Contain leakages (e.g. at the stem seal) of hazardous fluids (e.g. explosive, toxic, hot) so as to avoid any danger to persons and the environment. Adhere to all relevant laws.
- Eliminate all electrical hazards. (In this respect refer to the applicable national safety regulations and/or regulations issued by the local energy supply companies.)

2.8 Safety information for maintenance, inspection and installation







- Modifications or alterations of the valve require the manufacturer's prior consent.
- Use only original spare parts or parts authorised by the manufacturer. The use of other parts can invalidate any liability of the manufacturer for resulting damage.
- The operator ensures that maintenance, inspection and installation is performed by authorised, qualified specialist personnel who are thoroughly familiar with the manual.
- Carry out work on the valve during standstill only.
- The valve body must have cooled down to ambient temperature.
- The pressure in the valve body must have been released and the valve must have been drained.
- When taking the valve out of service always adhere to the procedure described in the manual. (↪ Section 7.2.1, Page 18)
- Decontaminate valves which handle fluids posing a health hazard.
- As soon as the work has been completed, re-install and re-activate any safety-relevant and protective devices. Before returning the product to service, observe all instructions on commissioning.







2.9 Unauthorised modes of operation

Never operate the valve outside the limits stated in the data sheet and in this operating manual.

The warranty relating to the operating reliability and safety of the valve supplied is only valid if the valve is used in accordance with its intended use.
(↪ Section 2.3, Page 8)

3 General safety regulations

	<p style="text-align: center;">DANGER</p> <p>Handling actuated valves Danger to life!</p> <ul style="list-style-type: none"> ▸ If the valves are fitted with actuators, ensure that the actuator's operating manual is also observed.
	<p style="text-align: center;">DANGER</p> <p>Surge pressure/water hammer potentially occurring at high temperatures Danger to life caused by burns or scalds!</p> <ul style="list-style-type: none"> ▸ The max. permissible valve pressure must not be exceeded (☞ Section 5, Page 14) . ▸ Use valves made of nodular cast iron or steel. ▸ Operator shall provide general safety measures for the system.
	<p style="text-align: center;">WARNING</p> <p>Fluids handled, consumables and supplies which are hot and/or pose a health hazard Hazard to persons and the environment!</p> <ul style="list-style-type: none"> ▸ Collect and properly dispose of flushing fluid and any fluid residues. ▸ Wear safety clothing and a protective mask if required. ▸ Observe all legal regulations on the disposal of fluids posing a health hazard.
	<p style="text-align: center;">WARNING</p> <p>Cold/hot piping and/or valve Risk of thermal injury!</p> <ul style="list-style-type: none"> ▸ Insulate the valve. ▸ Attach warning signs.
	<p style="text-align: center;">WARNING</p> <p>Impermissible piping forces Leakage from or rupture of the valve body!</p> <ul style="list-style-type: none"> ▸ Connect the pipes to the valve without transmitting any stresses or strains. ▸ Take constructional measures to prevent any piping forces from being transmitted to the valve.
	<p style="text-align: center;">WARNING</p> <p>Unqualified personnel performing work on the valve Risk of injury!</p> <ul style="list-style-type: none"> ▸ Always have repair and maintenance work performed by specially trained, qualified personnel.

	<p>CAUTION</p> <p>Condensation water forming in air-conditioning, cooling and refrigerating systems Ice forming! Blockage of actuating element! Damage due to corrosion!</p> <ul style="list-style-type: none"> ▷ Insulate the valve to prevent diffusion.
	<p>CAUTION</p> <p>Improper installation Damage to the valve!</p> <ul style="list-style-type: none"> ▷ Remove the caps prior to installation. ▷ Clean the mating flange faces. ▷ Protect the body and bonnet/cover from any impacts.
	<p>CAUTION</p> <p>Outdoor installation Damage due to corrosion!</p> <ul style="list-style-type: none"> ▷ Protect the valve appropriately against moisture.
	<p>CAUTION</p> <p>Painting of pipes Impairment of the valve's function and loss of information!</p> <ul style="list-style-type: none"> ▷ Protect stem and plastic components prior to applying paint. ▷ Protect printed name plates prior to applying paint.
	<p>CAUTION</p> <p>Impermissible load Damage to the actuating element!</p> <ul style="list-style-type: none"> ▷ Do not use the valve as a foothold.
	<p>CAUTION</p> <p>Improper reassembly Damage to the valve!</p> <ul style="list-style-type: none"> ▷ Reassemble the valve in accordance with the general rules of sound engineering practice. ▷ Use original spare parts only.

4 Transport/Temporary Storage/Disposal

4.1 Checking the condition upon delivery

1. On transfer of goods, check each packaging unit for damage.
2. In the event of in-transit damage, assess the exact damage, document it and notify KSB or the supplying dealer and the insurer about the damage in writing immediately.

4.2 Transport

The valves are delivered with the valve disc in the closed position. The valves are supplied ready for operation. Original spare parts are only ready for operation following assembly/installation and subsequent shell and leak testing of the valve.

4.3 Storage/preservation

If properly stored indoors, the equipment is protected for a maximum of 12 months. This allows commissioning to take place some time after delivery. We recommend that the following measures be taken:

- Store the valve in a dust-free and vibration-free, frost-proof room where the atmospheric humidity is as constant as possible (use suitable caps or film for protection).
- Close the valve using little force and store in the closed position.
- Protect the valve from contact with solvents, lubricants, fuels or other chemicals.

4.4 Return to supplier

1. Drain the valve as described in the manual.
2. Always flush and clean the valve, particularly if it has been used for handling noxious, explosive, hot or other hazardous fluids.
3. If the fluids handled by the system leave residues which might lead to corrosion damage when coming into contact with atmospheric humidity, or which might ignite when coming into contact with oxygen, the valve must also be neutralised and blown through with anhydrous inert gas for drying purposes.

4.5 Disposal

	WARNING
	<p>Fluids handled, consumables and supplies which are hot and/or pose a health hazard</p> <p>Hazard to persons and the environment!</p> <ul style="list-style-type: none">▷ Collect and properly dispose of flushing fluid and any fluid residues.▷ Wear safety clothing and a protective mask if required.▷ Observe all legal regulations on the disposal of fluids posing a health hazard.

1. Dismantle the valve. Collect greases and other lubricants during dismantling.
2. Separate and sort the valve materials, e.g. by:
 - Metals
 - Plastics
 - Electronic waste
 - Greases and other lubricants
3. Dispose of materials in accordance with current regulations or in another controlled manner.

5 Valve Description

5.1 General description

The sectional drawings below provide examples of the general design/configuration of the valve. For additional and more detailed information, refer to the respective type series booklet.

5.2 Marking

Table 4: General marking

Nominal size	DN ...
Nominal pressure class	PN ...
Flow direction arrow	→

5.3 Operating data

Table 5: Operating properties

Characteristic	Value
Nominal pressure	PN 16
Nominal size	DN 15-200
Max. permissible pressure [bar]	16
Min. permissible temperature [°C]	-10
Max. permissible temperature [°C]	+300

5.4 Fluids handled

- Hot or Overheated Water
- Low pressure Steam
- Other fluids on request.

5.5 Design details

Design

Valves to type series booklet I17111.1

- Straight-way pattern with Horizontal seat
- Spring loaded check disc
- Flange sto DIN EN 1092-2 type 21
- Exterior coating blue RAL 5002
- The Valves satisfy the safety requirements of Annex I of the European Pressure Equipment Directive 2014/68/EU (PED) for fluids in Group 1 and 2
- The valves do not have a potential internal source of ignition and can be used in potentially explosive atmospheres, Group II, category 2 (zone 1+21) and category 3 (zone 2+22) to ATEX 2014/34/EU

5.6 Pressure/temperature ratings

Table 6: Test pressure and operating pressure

PN	DN	Shell test	Leak test (seat)	Permissible operating pressure ⁴⁾
		With water		
		Tests P10 and P11 to DIN EN 12266-1	Test P12, leakage rate A to DIN EN 12266-1	-10 to +110 °C
		[bar]	[bar]	[bar]
16	15-200	24	18	16

5.7 Materials

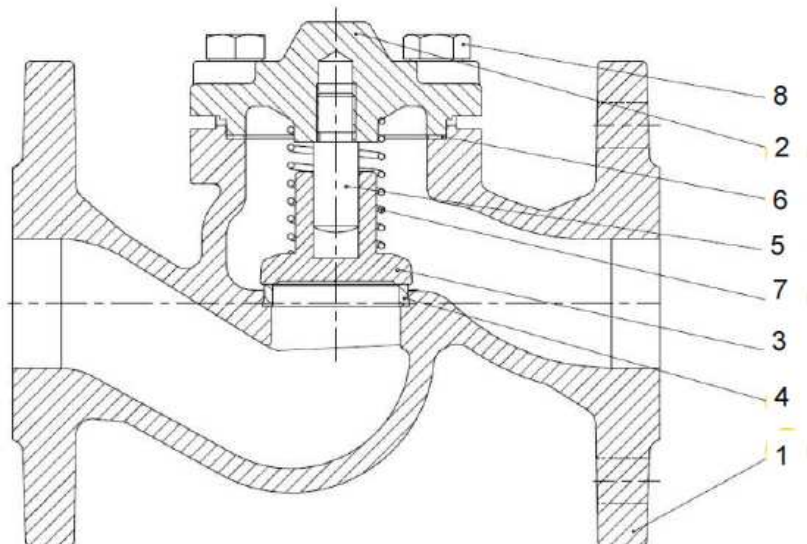

Fig. 2: ECOLINE-RA16

⁴⁾ Static load

Table 7: Overview of available materials

Part No.	Description	Material	Note
1	Body	EN-GJL-250	
2	Cover	EN-GJL-250	
3	Disc	X20Cr13	1.4021
4	Seat Ring	X20Cr13	1.4021
5	Stem	X20Cr13	1.4021
6	Gasket	Graphite CrNi	
7	Spring	X17CrNi 16-2	1.4057
8	Bolt	8.8	

5.8 Function

ECOLINE-RA16 is a spring-loaded check valve which closes automatically if fluid flow is reversed. The valve consists of the pressure-retaining parts, i.e. body (1) and body cover (2).

The functional consists of check disc (3) and spring (7). Check disc (3) is guided in and body cover (2). The position of check disc (3) is determined both by the flow conditions and by the spring (7).

5.9 Scope of supply

- Valve
- Operating manual for each packaging unit

5.10 Dimensions and weights

For dimensions and weights please refer to the type series booklet.

6 Installation at Site

6.1 General information/Safety regulations

Responsibility for positioning and installing the valve lies with the consultant, construction company or operator/user. Planning and installation errors may impair the reliable function of the valve and pose a substantial safety hazard.

6.2 Installation

A minimum pressure is required for opening. If this pressure is not reached, the spring can be dismantled.



NOTE

Flow through lift check valve must be in the direction of the arrow on the valve body. When equipped with a spring (7), they can be used in vertical pipes with upward or downward flow. Valves without spring can only be installed in a horizontal position, i.e. in horizontal pipes and with the body cover (2) pointing upwards

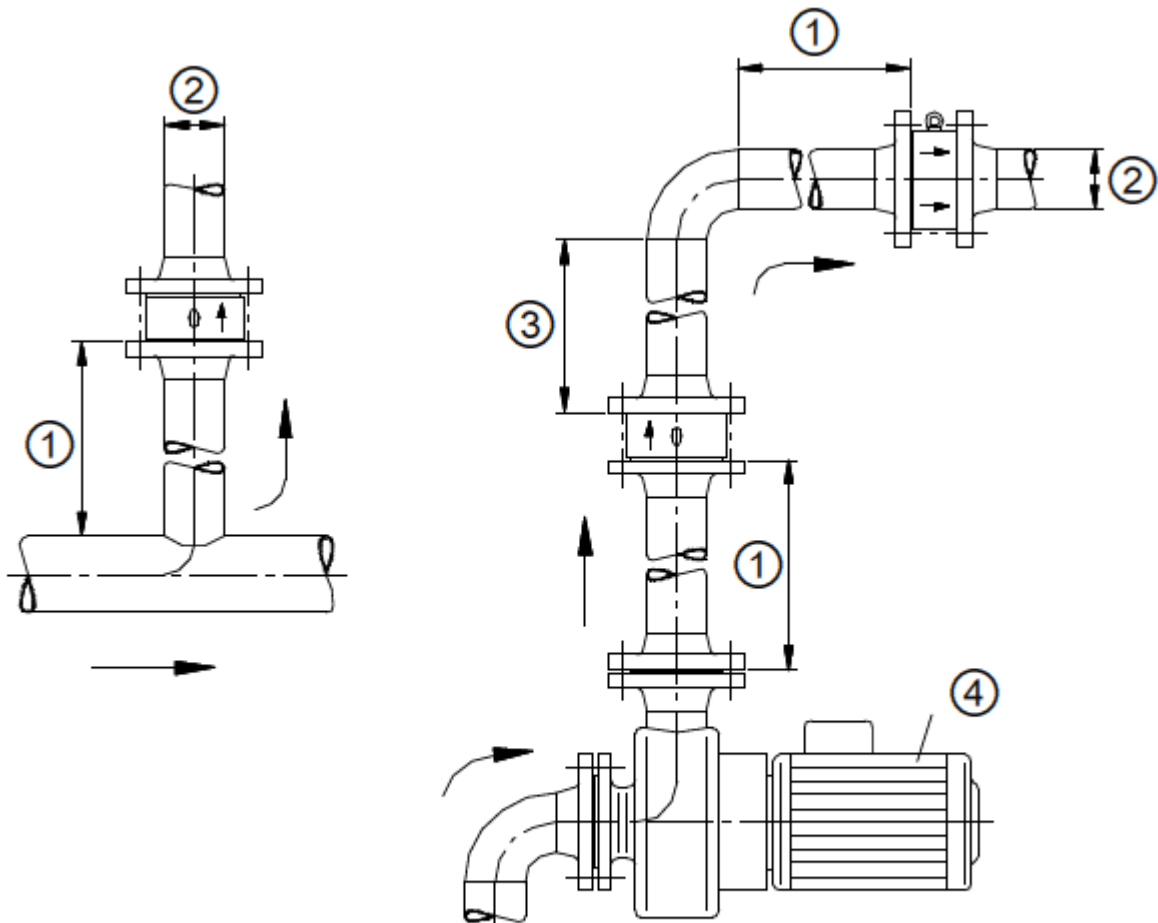

Fig. 8: Minimum upstream stabilisation distances

①	5x DN	②	DN
③	2x DN	④	Pump

7 Commissioning/Start-up/Shutdown

7.1 Commissioning/Start-up

7.1.1 Prerequisites for commissioning/start-up

Before commissioning/start-up of the valve, ensure that the following requirements are met:

- The material, pressure and temperature data shown on the valve is in compliance with the operating conditions of the piping. (☞ Section 5, Page 14)
- The material's chemical resistance and stability under load have been checked.



CAUTION

Welding beads, scale and other impurities in the piping

Damage to the valve!

- Remove any impurities from the piping.
- If necessary, install a strainer.

1. Thoroughly clean, flush and blow through all vessels, pipelines and connections (especially of new installations).
2. Remove the valve's flange covers before installing it in the piping.
3. Check that the inside of the valve is free from any foreign objects. Remove any foreign objects.
4. If required, install a strainer in the piping

Functional testing prior to commissioning/start-up

Check the shut-off function of the installed valve by opening and closing it several times.

Visual inspection after/during commissioning/start up

Check cover bolting (8) on ECOLINE-RA16 with gasket (6) for tightness after the valve has been subjected to load conditions or heated up for the first time. If leakage occurs or cover bolting is loose, evenly re-tighten it crosswise.

7.2 Shutdown

7.2.1 Measures to be taken for shutdown

During prolonged shutdown periods, ensure that the following conditions are met:

1. Drain fluids which change their physical condition due to changes in concentration, polymerisation, crystallisation, solidification, etc. from the piping.
2. If required, flush the piping with the valves fully opened.

8 Servicing/Maintenance

8.1 Safety regulations

	WARNING
	<p>Fluids, consumables and supplies which are hot and/or pose a health hazard Risk of injury!</p> <ul style="list-style-type: none"> ▷ Observe all relevant laws. ▷ When draining the fluid take appropriate measures to protect persons and the environment. ▷ Decontaminate valves used for handling fluids posing a health hazard.

	WARNING
	<p>Valve under pressure High-pressure hazard! Leakage of hot and/or toxic fluids! Risk of burns!</p> <ul style="list-style-type: none"> ▷ Never open the valve while it is pressurised. ▷ If there is fluid leakage, depressurise the valve. ▷ Ensure the valve is depressurised before removing any drain, opening or vent plugs. ▷ Ensure the valve is depressurised before removing it from the pipeline or before maintenance work. ▷ Allow the valve to cool down so that the temperature is below the fluid's vaporisation temperature in all areas in contact with the fluid in order to effectively prevent any risk of scalding.

Before removing the valve, ensure that the pipe has been shut off and released for repair/maintenance work.

A regular maintenance schedule will help avoid expensive repairs and contribute to trouble-free, reliable operation of the valve with a minimum of servicing/maintenance expenditure and work.

	NOTE
	<p>All maintenance, service and installation work can be carried out by KSB Service or authorised workshops. For contact details please refer to the enclosed "Addresses" booklet or visit "www.ksb.it" on the Internet.</p>

Never use force when dismantling and reassembling the valve.

8.2 Maintenance

The valve has been designed to be largely maintenance-free. The materials of the sliding parts have been selected to ensure minimum wear.

	NOTE
	<p>The user is responsible for defining appropriate intervals for checks and maintenance, depending on the application of the valve.</p>

The service life can be extended by taking the following measures:

- Checking the function by opening and closing the valve at least once or twice a year
- Re-tightening or replacing the bonnet/cover gasket (6) in good time.

9 Trouble-shooting

	WARNING
	<p>Improper remedial work on the valve Risk of injury!</p> <p>▷ For any work performed in order to remedy faults on the valve observe the relevant information given in this operating manual and/or the product literature provided by the accessories manufacturers.</p>

If problems occur that are not described in the following table, consultation with the KSB customer service is required.

Table 8: Trouble-shooting

Problem	Remedy
Leakage at the bonnet/cover gasket	Re-tighten the screwed bonnet and/or fit a new joint ring.

Index

C

Commissioning 18

D

Design details
ECOLINE-RA16 15

Disposal 13

F

Faults
Causes and remedies 21

Function
ECOLINE-RA16 16

I

Intended use 8

M

Maintenance 19

Marking 14
Materials
ECOLINE-RA16 16

Misuse 8

O

Operating data
ECOLINE-RA16 14

Operating ranges 8

Other applicable documents 6

P

Pressure/temperature ratings
ECOLINE-RA16 15

R

Return to supplier 12

S

Safety 7

Safety awareness 8

Scope of supply 16

Shutdown 18

Storage 12



KSB Italia SpA

Via M. D'Azeglio 32 • 20863 Concorezzo MB (Italy)

Tel. +39 039 60481

www.ksb.com