

Foot Check Valve

## ECOLINE-FND

PN 10  
DN 50-300

### Type Series Booklet



Foot check valve with suction strainer  
PN 10

## ECOLINE - FND



### Materials

Part Name	Material	Mat. No. compliant with EN/DIN standards
Body	EN-GJS-400-15	
Suction strainer	AISI 304	
Seat	EPDM	
Disc	EN-GJS-400-15	

### Applications

- Heating systems
- Water supply systems
- Air conditioning systems

### Operating limits

Temperature from **-10°C** to **+90°C**  
 Maximum Allowable Pressure **10 bar**

### Design

- Foot valve with suction strainer
- Flanges compliant to EN 1092-2 PN 10
- Suction strainer bottom with no holes compliant with DIN 3259 standards
- Holed suction strainer with 8mm diameter holes
- Painted with blue water based paint RAL 5002, 70 micron thickness

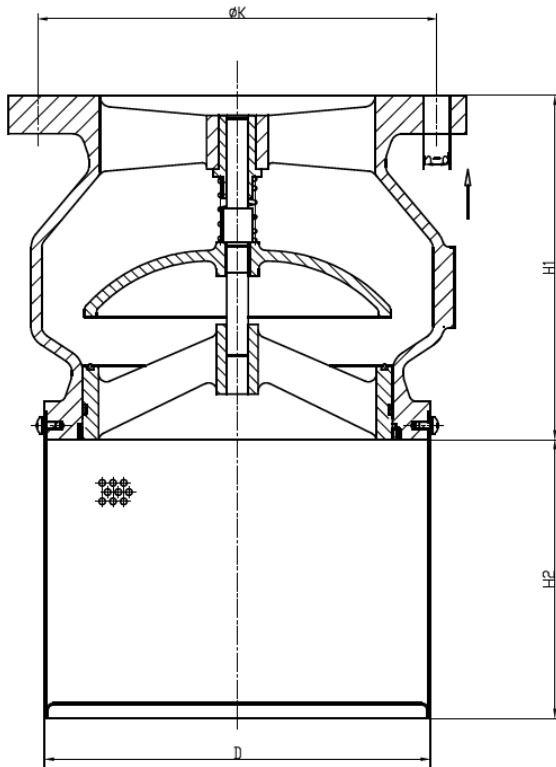
**Dimensions**

Dimensions in mm

PN	DN	H1	H2	K	D	d	n	Weight[kg]
10	50	133	68	125	114	19	4	9,5
	65	140	93	145	130	19	4	12,5
	80	152	108	160	144	19	4	18,0
	100	185	138	180	177	19	8	26,0
	125	216	163	210	203	19	8	32,0
	150	229	187,9	240	237	23	8	43,0
	200	257	208	295	290	23	8	74,0
	250	293	225	350	330	23	12	107,0
	300	362	245	400	383	23	12	150,0