

Butterfly Valve

# DANAIS 150

DN 50 - 1200  
PS 25 bar

## Type Series Booklet



## **Legal information/Copyright**

Type Series Booklet DANAÏS 150

All rights reserved. The contents provided herein must neither be distributed, copied, reproduced, edited or processed for any other purpose, nor otherwise transmitted, published or made available to a third party without the manufacturer's express written consent.

Subject to technical modification without prior notice.

© KSB S.A.S, Gennevilliers (Paris), France 06/07/2021

## Contents

<b>Butterfly Valves.....</b>	<b>4</b>
Double-offset Butterfly Valves.....	4
DANAIS 150 .....	4
Main applications.....	4
Medien.....	4
Operating data.....	4
Design details.....	4
Valve body materials.....	5
Product benefits.....	5
Product information .....	5
Product information as per Pressure Equipment Directive 2014/68/EU (PED).....	5
EC Machinery Directive 2006/42/EC.....	5
Product information as per Regulation No. 1907/2006 (REACH) .....	5
Product information as per Directive 2014/34/EU (ATEX).....	5
Certification.....	5
Related documents .....	5
Purchase order specifications .....	6
Pressure/temperature ratings.....	7
Technical data .....	8
Kinematics .....	8
Shut-off.....	9
Actuating torque.....	9
Actuating torques for elastomer-seated or metal-seated valves.....	9
Actuating torques for metal-seated valves .....	10
Hydraulic characteristics .....	10
Fire-safe design .....	11
Extension option .....	12
Configuration of DANAIS 150 .....	13
Materials.....	14
Components in common.....	14
Detail views of all seat types .....	17
Variants.....	20
Dimensions .....	21
Dimensions of DANAIS 150 with wafer-type body with flat faces - T1 .....	21
Dimensions of DANAIS 150 with full-lug body – T4.....	22
Line connections.....	23
Installation information.....	25
Dead-end service and downstream dismantling.....	25
Definition of sealing element .....	26
Bolting and weights.....	28
Bolting and weights for wafer-type body with flat faces - T1 .....	28
Bolting and weights for full-lug body – T4 .....	32

## Butterfly Valves

### Double-offset Butterfly Valves

## DANAIS 150



#### Main applications

- Hot-water heating systems
- District heating
- Chemical industry
- Air-conditioning systems
- Beverage industry and food industry
- Paper industry / pulp industry
- Petrochemical industry
- Pharmaceutical industry
- Shipbuilding
- Mining
- Pipelines and tank farms
- Process engineering
- Refinery
- Sugar industry
- Pressure boosting
- Industrial recirculation systems
- Low-pressure steam
- Gases

#### Medien

- Fuels
- Hot water
- High-temperature hot water
- Fluids containing mineral oils
- Solids-laden fluids
- Aggressive fluids
- Heat transfer fluids / Oils
- Corrosive fluids

- Flammable fluids
- Toxic fluids
- Volatile fluids
- Gas
- Oil
- Solids (ore, sand, gravel, ash)
- Steam
- Vacuum

#### Operating data

Table 1: Operating properties

Parameter	Value
Nominal pressure	PN 10/16/25
Nominal pressure	Class 150
Nominal size [mm]	DN 50 - 1200
Nominal size [inch]	NPS 2-48
Max. permissible pressure [bar]	25
Min. permissible temperature [°C]	≥ -50
Max. permissible temperature [°C]	≤ +260
Actuation at ΔP	Limited to 20 bar (16 bar for elastomer seat)
Vacuum operation down to	0 bar absolute
Max. permissible flow velocity at operating pressure	4 m/s for liquids 50 m/s for clean gases

The operating temperature depends on the seat material (⇒ Page 7) and on the packing material. (⇒ Page 17). For temperatures > 260 °C contact KSB.

#### Design details

##### Design

- Wafer-type body with flat faces - T1: DN 50 - 1200 (2 - 48 in.)
- Full-lug body with raised faces – T4: DN 50 - 1200 (2 - 48 in.)
- Four interchangeable seat types: plastomer, fire-safe plastomer, metal or elastomer
- Dead-end service and downstream dismantling possible with full-lug bodies T4.
- Face-to-face length to EN 558 Series 20, ISO 5752 Series 20 (except DN 350: EN 558 / ISO 5752 Series 25) and API 609 Table 2 Class 150
- EN, ASME, JIS connections
- Marking in accordance with EN 19
- Absolutely tight shut-off (no leakage visible to the naked eye) in either direction of flow in accordance with EN 12266-1, leakage rate A, and ISO 5208, category A.
- Steel body: anti-corrosive primer coat and optional two-layer or three-layer coating system
- Stainless steel body: pickled and passivated
- Fire-safe to API 607
- The valves meet the fugitive emission requirements specified in TA Luft (German Technical Guidelines on Air Quality Control, VDI 2440) and standard ISO 15848-1 (CO3 Class B).

### Variants

- S / SR / SP / CR / CM quarter-turn levers
- MR manual gearbox
- ACTAIR NG / DYNACTAIR NG pneumatic actuators
- Electric quarter-turn actuators
- HQ hydraulic actuators
- AMTROBOX for open/closed position signalling
- AMTRONIC position signalling and control air supply
- SMARTRONIC positioner and process controller
- Other actuators on request
- Anti-static design for manually actuated valves

### Valve body materials

**Table 2:** Overview of materials available for wafer-type body T1 and full-lug body T4

Material	Material number	Temperature limit	KSB code
Carbon steel	ASTM A216 Gr. WCC / 1.0619	-29 °C to +260 °C	1
Stainless steel	ASTM A351 Gr. CF 8M / 1.4408	-50 °C to +260 °C	6
Stainless steel	ASTM A351 Gr. CF 3M / 1.4409	-50 °C to +260 °C	6t
Stainless steel	ASTM A351 Gr. CF3M Mo > 2.75	-50 °C to +260 °C	6m
Nodular cast iron (only for body type T1 and DN 80 to 800)	ASTM A536 Gr. 60-40-18	-10 °C to +260 °C	3g
High-strength stainless steel	ASTM A351 Gr. CK3MCuN (254SMO)	-29 °C to +260 °C	7d

### Product benefits

- Gland packing can be replaced without removing the bracket:
  - Service-friendly
  - Cost-saving
- Shaft in anti-blowout design
  - Actuator can be removed safely
  - Protection of persons
- Shaft perfectly guided by long bearings
  - Tight shut-off: The highest sealing capability on the market, even at full pressure rating
- Valve body without separate bottom cover (up to DN 300)
  - Reliable sealing to atmosphere
- Smooth flange
  - Excellent sealing at the flanged line connections
- Closed-position travel stop
  - Protects seat from damage in the event of improper operation
- Patented seat design
  - Tight shut-off: The highest sealing capability on the market, even at full pressure rating
  - Long service life
  - Service-friendly
- Body seat protected against abrasion
  - Long service life of the seat
- Wafer-type body with centring ribs
  - For greater ease of installation between a variety of flange types

### Product information as per Regulation No. 1907/2006 (REACH)

For information as per chemicals Regulation (EC) No. 1907/2006 (REACH), see <https://www.ksb.com/ksb-en/About-KSB/Corporate-responsibility/reach/>.

### Product information as per Directive 2014/34/EU (ATEX)

The valves do not have a potential internal source of ignition and can be used in potentially explosive atmospheres, Group II, category 2 (zones 1+21) to ATEX 2014/34/EU.

### Certification

**Table 3:** Overview

Label	Effective in:	Comment
	Worldwide	
	Worldwide	Approved for marine applications
	Worldwide	Approved for marine applications
	Worldwide	Approved for marine applications
	Worldwide	Approved for marine applications
	Worldwide	FDA-compliant elastomer material
	Europe	Certificate regarding food contact materials as per European Regulation (EC) No. 1935/2004

### Product information

#### Product information as per Pressure Equipment Directive 2014/68/EU (PED)

The valves satisfy the safety requirements of Annex I of the European Pressure Equipment Directive 2014/68/EU (PED) for fluids in Groups 1 and 2.

#### EC Machinery Directive 2006/42/EC

Valves with actuators can meet the requirements of the 2006/42/EC Machinery Directive for partly completed machinery.

### Related documents

**Table 4:** Information/documents

Document	Reference number
Actuator selection	8460.15
Operating manual	8450.810

### Purchase order specifications

1. Type
2. Nominal pressure
3. Nominal size
4. Fluid handled
5. Flow rate / flow velocity
6. Operating temperature
7. Materials (body, valve disc, seat)
8. Line connection, flange facing and flange surface quality
9. Actuator / automation
10. Reference number

**Pressure/temperature ratings**
**Pressure classes PN 10, PN 16, PN 25**

In pressure classes PN 10, PN 16 and PN 25 (European materials), the DANAIS 150 butterfly valve meets the requirements of EN 12516-1.

The values in the following table are valid for valves to European Pressure Equipment Directive 2014/68/EU:

**Table 5: Pressure/temperature ratings for pressure classes PN 10, PN 16, PN 25**

Pressure class	Materials		Operating pressure in [bar] at a temperature in [°C]										
	Body	Seat	-50	-10	0	20	100	135	150	180	200	220	260
PN 10	Carbon steel 1.0619	Plastomer <sup>1)</sup>	<sup>2)</sup>	9,7	9,7	9,7	8,5	8,1	7,9	7,4	3,3	0,0	<sup>2)</sup>
		Elastomer <sup>3)</sup>	<sup>2)</sup>	9,7	9,7	9,7	8,5	<sup>2)</sup>	<sup>2)</sup>	<sup>2)</sup>	<sup>2)</sup>	<sup>2)</sup>	<sup>2)</sup>
		Stainless steel 301	<sup>2)</sup>	9,7	9,7	9,7	8,5	8,1	7,9	7,4	7,1	6,9	6,4
	Stainless steel 1.4408	Plastomer <sup>1)</sup>	<sup>2)</sup>	9,7	9,7	9,7	8,3	7,7	7,5	7,1	3,3	0,0	<sup>2)</sup>
		Stainless steel 301	9,7	9,7	9,7	8,3	7,7	7,5	7,1	6,9	6,7	6,3	
		Pure plastomer <sup>4)</sup>	9,7	9,7	9,7	8,3	7,7	7,5	<sup>2)</sup>	<sup>2)</sup>	<sup>2)</sup>	<sup>2)</sup>	
	Stainless steel 1.4409	Plastomer <sup>1)</sup>	<sup>2)</sup>	9,0	9,0	8,9	7,8	7,3	7,1	7,1	3,3	0,0	<sup>2)</sup>
		Pure plastomer <sup>4)</sup>	9,0	9,0	9,0	8,9	7,8	7,3	7,1	<sup>2)</sup>	<sup>2)</sup>	<sup>2)</sup>	<sup>2)</sup>
	PN 16	Carbon steel 1.0619	Plastomer <sup>1)</sup>	<sup>2)</sup>	15,6	15,6	15,6	13,6	13,0	12,7	10,0	3,3	0,0
Elastomer <sup>3)</sup>			<sup>2)</sup>	15,6	15,6	15,6	13,6	<sup>2)</sup>	<sup>2)</sup>	<sup>2)</sup>	<sup>2)</sup>	<sup>2)</sup>	<sup>2)</sup>
Stainless steel 301			<sup>2)</sup>	15,6	15,6	15,6	13,6	13,0	12,7	11,9	11,4	11,0	10,2
Stainless steel 1.4408		Plastomer <sup>1)</sup>	<sup>2)</sup>	15,5	15,5	15,5	13,3	12,4	12,0	10,0	3,3	0,0	<sup>2)</sup>
		Stainless steel 301	15,5	15,5	15,5	13,3	12,4	12,0	11,4	11,0	10,7	10,1	
		Pure plastomer <sup>4)</sup>	15,5	15,5	15,5	13,3	12,4	12,0	<sup>2)</sup>	<sup>2)</sup>	<sup>2)</sup>	<sup>2)</sup>	
Stainless steel 1.4409		Plastomer <sup>1)</sup>	<sup>2)</sup>	15,5	15,5	15,5	13,3	12,4	11,4	10,0	3,3	0,0	<sup>2)</sup>
		Pure plastomer <sup>4)</sup>	15,5	15,5	15,5	13,3	12,4	11,4	<sup>2)</sup>	<sup>2)</sup>	<sup>2)</sup>	<sup>2)</sup>	
PN 25		Carbon steel 1.0619	Plastomer <sup>1)</sup>	<sup>2)</sup>	24,4	24,4	24,4	21,3	20,3	15,8	10,0	3,3	0,0
	Stainless steel 301		<sup>2)</sup>	24,4	24,4	24,4	21,3	20,3	19,8	18,6	17,8	17,2	15,9
	Stainless steel 1.4408	Plastomer <sup>1)</sup>	<sup>2)</sup>	24,3	24,3	24,3	20,7	19,3	15,8	10,0	3,3	0,0	<sup>2)</sup>
		Stainless steel 301	24,3	24,3	24,3	20,7	19,3	18,7	17,8	17,2	16,7	15,8	
		Pure plastomer <sup>4)</sup>	24,3	24,3	24,3	20,7	19,3	15,8	<sup>2)</sup>	<sup>2)</sup>	<sup>2)</sup>	<sup>2)</sup>	
	Stainless steel 1.4409	Plastomer <sup>1)</sup>	<sup>2)</sup>	22,5	22,5	22,5	19,5	19,3	17,8	10,0	3,3	0,0	<sup>2)</sup>
		Pure plastomer <sup>4)</sup>	22,5	22,5	22,5	19,5	19,3	17,8	<sup>2)</sup>	<sup>2)</sup>	<sup>2)</sup>	<sup>2)</sup>	

**Pressure class 150**

In pressure class 150 (ASTM materials), the DANAIS 150 valve complies with ASME B16.34 Class 150 "Standard Class" as per the following table (except for ASTM A536 Gr. 60-40-18):

**Table 6: Pressure/temperature ratings for pressure class 150**

Pressure class	ASTM materials		Operating pressure in [bar] at a temperature in [°C]											
	Body	Seat	-50	-29	-10	0	50	100	135	150	180	200	220	260
Class 150	A216 Gr. WCC	Plastomer <sup>1)</sup>	<sup>2)</sup>	<sup>2)</sup>	20,0	20,0	20,0	17,7	16,4	15,8	10,0	3,3	0,0	<sup>2)</sup>
		Elastomer <sup>3)</sup>	<sup>2)</sup>	<sup>2)</sup>	20,0	20,0	20,0	17,7	<sup>2)</sup>	<sup>2)</sup>	<sup>2)</sup>	<sup>2)</sup>	<sup>2)</sup>	<sup>2)</sup>
		Stainless steel 301	<sup>2)</sup>	20,0	20,0	20,0	20,0	17,7	16,4	15,8	14,7	13,8	13,2	11,7
	A351 Gr. CF8M	Plastomer <sup>1)</sup>	<sup>2)</sup>	<sup>2)</sup>	19,0	19,0	18,4	16,2	15,2	14,8	10,0	3,3	0,0	<sup>2)</sup>
		Stainless steel 301	19,0	19,0	19,0	18,4	16,2	15,2	14,8	14,2	13,7	13,0	11,7	
		Pure plastomer <sup>4)</sup>	19,0	19,0	19,0	18,4	16,2	15,2	14,8	<sup>2)</sup>	<sup>2)</sup>	<sup>2)</sup>	<sup>2)</sup>	
	A351 Gr. CK3MCUN	Plastomer <sup>1)</sup>	<sup>2)</sup>	<sup>2)</sup>	20,0	20,0	19,5	17,7	16,4	15,8	10,0	3,3	0,0	<sup>2)</sup>
	A351 Gr. CF3M A351 Gr. CF3M Mo > 2,75 %	Plastomer <sup>1)</sup>	<sup>2)</sup>	<sup>2)</sup>	19,0	19,0	18,4	16,2	15,2	14,8	10,0	3,3	0,0	<sup>2)</sup>
		Pure plastomer <sup>4)</sup>	19,0	19,0	19,0	18,4	16,2	15,2	14,8	<sup>2)</sup>	<sup>2)</sup>	<sup>2)</sup>	<sup>2)</sup>	
	A536 Gr. 60-40-18	Elastomer <sup>3)</sup>	<sup>2)</sup>	<sup>2)</sup>	17,2	17,2	17,2	16,2	<sup>2)</sup>	<sup>2)</sup>	<sup>2)</sup>	<sup>2)</sup>	<sup>2)</sup>	<sup>2)</sup>

<sup>1)</sup> Plastomer = PTFE / PTFE fire-safe (glass-fibre reinforced PTFE)

<sup>2)</sup> Not permitted

<sup>3)</sup> Elastomer = VITON (FKM) / NBR

<sup>4)</sup> Pure plastomer = pure PTFE / pure PTFE fire-safe

## Technical data

### Kinematics

- The valve disc is pressed onto the seat by double-offset kinematics.
- Double offset:
  - The axis of rotation is offset from the seat/disc interface.
  - The axis of rotation is offset from the piping centreline.
- This design prevents friction between the seat and the sealing surface of the valve disc as the valve discs opens and closes.
- The valve's shut-off capability is maintained even after a very large number of actuating cycles.
- The butterfly valve's shut-off capability meets the most stringent specifications and standards.

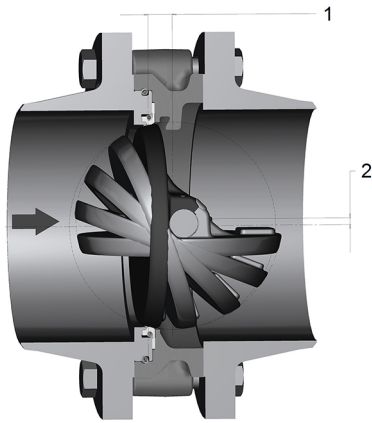

Schematic  
Cross-section perpendicular to shaft

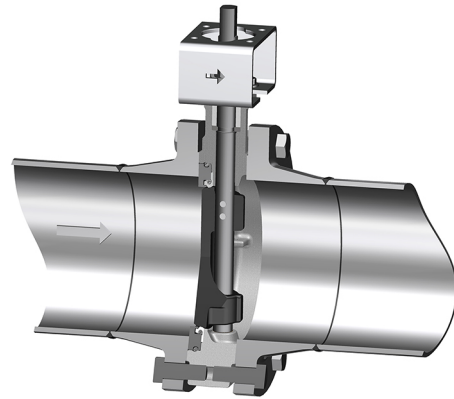

Schematic  
Cross-section parallel to shaft

1. First offset
2. Second offset



### Shut-off

- The valve complies with the standards listed below.
- The valve is bi-directional, with a preferred flow direction indicated by the arrow on the yoke (direction of differential pressure applied to valve disc).

**Table 7:** Shut-off table

Valve	Plastomer-seated or elastomer-seated	Metal-seated
For liquids	EN 12266-1 Leakage rate A ISO 5208 Category A API 598	EN 12266-1 Leakage rate D ISO 5208 Category D MSS SP 61
For gases	EN 12266-1 Leakage rate A ISO 5208 Category A API 598 ANSI / FCI 70.2 Class VI	EN 12266-1 Leakage rate D ISO 5208 Category D MSS SP 61

### Actuating torque

A safety coefficient has already been included in the actuating torques for actuator selection.

### Actuating torques for plastomer-seated or elastomer-seated valves

**Table 8:** Table of actuating torques for plastomer-seated or elastomer-seated valves [Nm]

DN	NPS [inch]	Differential pressure $\Delta P$ [bar]							
		Preferred flow direction				Non-preferred flow direction			
		6	10	16	20	6	10	16	20
50	2	20	20	30	30	20	20	20	20
65	2½	30	30	30	40	20	20	30	30
80	3	30	40	40	50	30	30	40	40
100	4	50	50	60	70	40	50	60	70
125	5	70	80	90	100	60	70	90	100
150	6	100	110	140	160	90	110	140	160
200	8	160	180	230	260	150	190	240	280
250	10	290	340	440	510	270	350	470	550
300	12	400	470	620	720	380	500	680	790
350	14	610	720	970	1140	570	780	1080	1290
400	16	820	980	1340	1570	780	1060	1490	1770
450	18	1130	1370	1880	2210	1080	1480	2090	2490
500	20	1380	1680	2310	2740	1320	1820	2570	3070
550 <sup>5)</sup>	22	1820	2220	3100	3690	1740	2450	3510	4220
600	24	2210	2720	3820	4560	2130	3000	4320	5200
650	26	2590	3200	4510	<sup>6)</sup>	2970	4050	5660	<sup>6)</sup>
700	28	2900	3630	5130	<sup>6)</sup>	3810	5090	7000	<sup>6)</sup>
750	30	3670	4580	6530	<sup>6)</sup>	4530	6390	8950	<sup>6)</sup>
800	32	4300	5350	7660	<sup>6)</sup>	5460	7410	10340	<sup>6)</sup>
900	36	5600	7040	10130	<sup>6)</sup>	7150	9740	13630	<sup>6)</sup>
1000	40	7500	9510	13820	<sup>6)</sup>	9450	13060	18470	<sup>6)</sup>
1200	48	11450	14670	21540	<sup>6)</sup>	16200	21670	32350	<sup>6)</sup>

<sup>5</sup> DN 550 is available for elastomer-seated valves with body type T1 made of nodular cast iron or carbon steel (WCC).

<sup>6</sup> Contact KSB.

**Actuating torques for metal-seated valves**
**Table 9:** Table of actuating torques for metal-seated valves [Nm]

DN	NPS	Differential pressure $\Delta P$ [bar]															
		Preferred flow direction								Non-preferred flow direction							
		Liquid fluid				Non-liquid fluid				Liquid fluid				Non-liquid fluid			
		[inch]	6	10	16	20	6	10	16	20	6	10	16	20	6	10	16
50	2	20	30	30	30	40	50	60	60	20	30	30	30	40	50	60	60
65	2½	30	40	40	50	60	70	80	90	30	40	40	50	60	70	80	90
80	3	40	50	60	60	80	90	110	120	40	50	60	60	80	90	110	120
100	4	70	80	90	100	130	150	180	190	70	80	90	100	130	150	180	190
125	5	90	110	130	150	190	220	260	280	90	110	130	150	190	220	260	280
150	6	140	170	210	230	280	320	380	420	140	170	210	230	280	320	380	420
200	8	250	290	350	400	500	560	660	730	240	290	360	410	480	560	670	740
250	10	430	490	620	710	820	920	1100	1220	410	500	650	750	800	930	1130	1270
300	12	590	680	860	990	1130	1260	1510	1680	560	700	920	1060	1100	1290	1560	1750
350	14	860	1000	1290	1490	1590	1790	2160	2420	820	1050	1400	1630	1550	1840	2270	2560
400	16	1170	1360	1770	2040	2140	2410	2930	3280	1120	1440	1920	2240	2090	2480	3080	3470
450	18	1590	1870	2450	2830	2900	3280	4000	4480	1530	1980	2660	3110	2840	3390	4210	4750
500	20	1920	2270	2990	3460	3480	3950	4840	5430	1860	2410	3240	3790	3420	4090	5090	5760
600	24	2980	3560	4760	5560	5220	5950	7380	8340	2890	3830	5290	6190	5130	6230	7880	8970

**Hydraulic characteristics**
**Table 10:** Table [Kv0 in m<sup>3</sup>/h / bar<sup>0.5</sup>] and [Cv0 in GUS / min / psi<sup>0.5</sup>]

DN	NPS	Flow coefficient with valve disc fully open		Zeta	
		[inch]	Kv0		Cv0
50	2		70	80	2,04
65	2½		110	145	2,35
80	3		190	220	1,81
100	4		340	400	1,38
125	5		600	700	1,08
150	6		980	1150	0,84
200	8		1850	2150	0,75
250	10		3350	3880	0,56
300	12		4870	5650	0,55
350	14		7070	8200	0,48
400	16		10350	12000	0,38
450	18		12500	14500	0,42
500	20		15090	17500	0,44
550	22		18750	21750	0,42
600	24		22410	26000	0,41
650	26		24655	28600	0,47
700	28		26900	31200	0,53
750	30		32600	37820	0,48
800	32		38000	44100	0,45
900	36		59100	68600	0,30
1000	40		76700	89000	0,27
1200	48		143000	165880	0,16

**Fire-safe design**

Lloyd's Register certified design to API 607 (and to EN ISO 10497 for aluminium bronze variant)

Design:

**Tight shut-off**

Plastomer seat (1) and fire-safe metal seat made of stainless steel (2)

1. Plastomer seat
2. Disc spring-type fire-safe metal seat

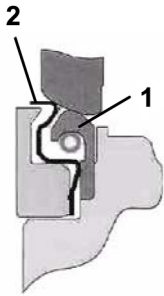

**Valve before it is flanged into the piping**

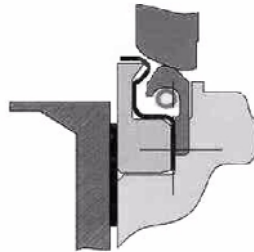

**Valve flanged into the piping during normal operation (before fire event)**

When the valve is clamped between the flanges, the fire-safe metal seat straightens. There is no contact between the fire-safe metal seat and the valve disc. Shut-off is ensured by the plastomer seat.

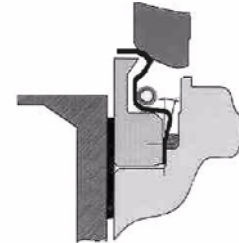

**Valve flanged into the piping (after fire event)**

The fire destroys the plastomer seat. The metal seat resumes its original shape and contacts the valve disc. During the fire, the metal seat ensures continued shut-off. The leakage rate is compliant with API 607 or EN ISO 10497.

Fire-safe design is recommended for body type T4 (full-lug body).

In the event of a fire, the flange bolting is thermally isolated and protected by the body lugs.

This protection limits bolt deformation in a fire, thus maintaining the sealing effect of the flange gaskets.

**Sealing at the Shaft passage**

Expanded graphite gland packing

### Extension option

For DN 50 to 600 (up to DN 800 for nodular cast iron)

This option is recommended for applications in aggressive environments (marine, petrochemical industry, etc).

The extension replaces the bracket/gland follower assembly and protects the valve/actuator interface against the environment.

O-rings made of Viton provide a back-up seal at the shaft passage.

Max. operating temperature: +220 °C

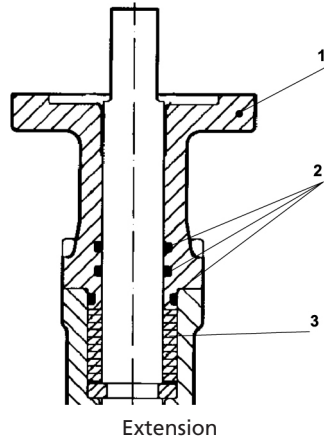

- 1: Top flange to ISO 5211
- 2: Back-up seal by O-rings made of VITON (FKM)
- 3: Primary sealing by expanded graphite gland packing

## Configuration of DANAIS 150

Table 11: Overview of configuration options

Material type	ASTM material code	EN material code	KSB code	DANAIS 150			
				General industry (Standard) DN 50-1200 (2 - 48 in.) Body types T1 and T4	Crude oil (Variant C) DN 80-800 (3 - 32 in.) Body types T1 and T4	Mining (Variant D) DN 65-600 (2 ½ - 24 in.) Body types T1 and T4	Chemical tankers (Variant T) DN 50-450 (2 - 18 in.) Body types T1 and T4
<b>BODY</b>							
Stainless steel	A351 Gr. CF8M	1.4408	6	✓	-	-	✓
Stainless steel	A351 Gr. CF3M	1.4409	6t	-	-	-	✓
Stainless steel	A351 Gr. CF3M Mo > 2,75 %		6m	-	-	-	✓
High-strength stainless steel (duplex)	A351 Gr. CK3MCuN (254 SMO)		7d	-	-	✓	-
Nodular cast iron (body type T1 only)	A536 Gr. 60-40-18		3g	-	✓	-	-
Carbon steel	A216 Gr. WCC	1.0619	1	✓	✓	-	-
<b>SHAFT AND AXLE</b>							
Stainless steel	A564 Gr. 630	1.4542	6e	✓	-	-	✓
Stainless steel	AISI 431	1.4057	6h	-	✓	-	-
Stainless steel (duplex)		1.4462	7e (0-16 bar)	✓	-	-	✓
Stainless steel	A479 Gr. 316L		6 (0-10 bar)	✓	-	-	-
Stainless steel (duplex)		1.4547	7d	-	-	✓	-
<b>VALVE DISC</b>							
Stainless steel <sup>7)</sup>	A351 Gr. CF8M	1.4408	6	✓	✓	-	✓
Stainless steel <sup>7)</sup>	A351 Gr. CF3M	1.4409	6t	-	-	-	✓
Stainless steel <sup>7)</sup>	A351 Gr. CF3M Mo > 2,75 %		6m	-	-	-	✓
Aluminium bronze	B148 Gr. C95400		2a	-	✓	-	-
High-strength stainless steel	A351 Gr. CK3MCuN (254 SMO)		7d	-	-	✓	-
<b>SEAT</b>							
<b>Plastomer seat</b>							
PTFE, glass fibre reinforced			FB	✓	-	✓	✓
PTFE, glass fibre reinforced + fire-safe		PTFE + 1.4404	FF	✓	-	-	✓
Pure PTFE (DN 50-600)			FC	✓	-	-	✓
Pure PTFE + fire-safe (DN 50-600)		PTFE + 1.4404	FI	✓	-	-	✓
<b>Elastomer seat</b>							
Viton (FKM)			VD	-	✓	-	-
Nitrile (NBR)			KD	-	✓	-	-
<b>Metal seat</b>							
Stainless steel (301)		1.4310	6a	✓	-	-	-

<sup>7)</sup> For fire-safe plastomer seat or metal seat: Use chrome-plated valve disc.

Materials

Components in common

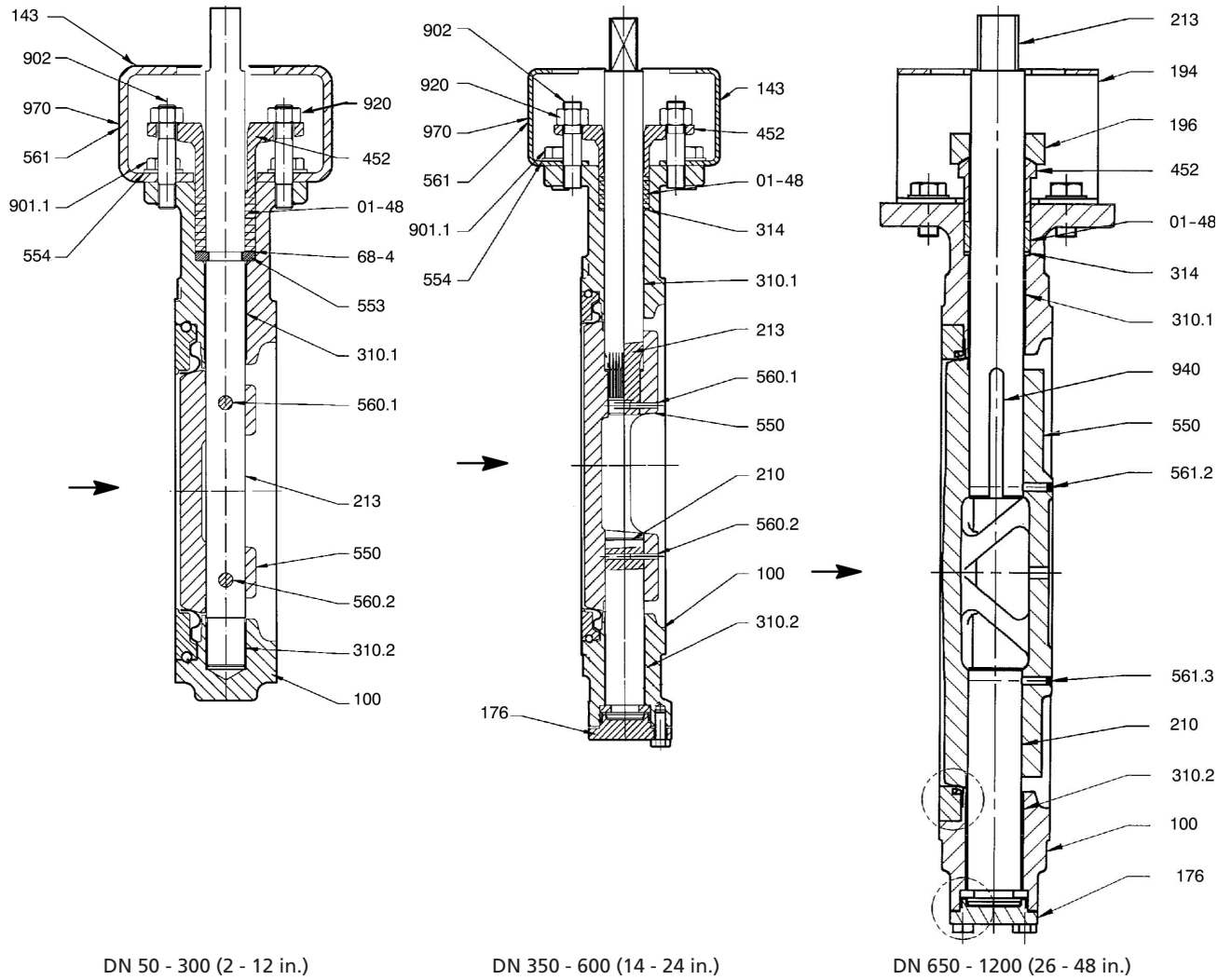

➔ Preferred flow direction

Extension option

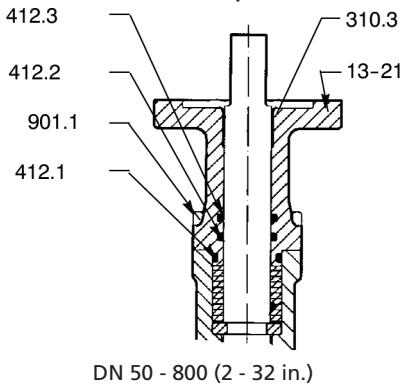

Detail of bottom

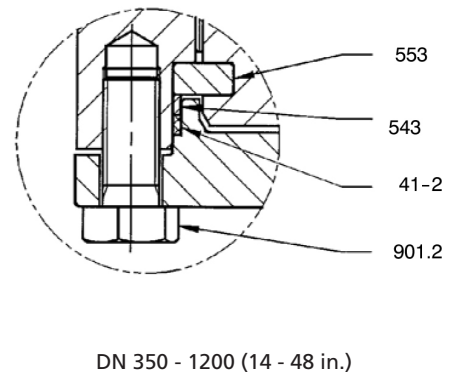

**Table 12:** List of components in common

Part No.	Description	DN	Materials	Temperature	KSB code
01-48	Gland packing	50-1200	Depending on type of seat 144.1	Depending on type of gland packing	
100	Wafer-type body with flat faces (T1) and full-lug body with raised faces (T4)	50-1200	Carbon steel A216 Gr. WCC / 1.0619	-29 °C to +260 °C	1
		50-1200	Stainless steel ASTM A351 Gr. CF8M / 1.4408	-50 °C to +260 °C	6
		80-800	Nodular cast iron ASTM A536 Gr. 60-40-18 (body type T1 only)	-10 °C to +260 °C	3g
		50-600	High-strength stainless steel ASTM A351 Gr. CK3MCuN (254SMO)	-29 °C to +260 °C	7d
		50-450	Stainless steel ASTM A351 Gr. CF3M / 1.4409	-50 °C to +260 °C	6t
		50-450	Stainless steel ASTM A351 Gr. CF3M Mo > 2,75 %	-50 °C to +260 °C	6m
176	Bottom	350-1200	Stainless steel ASTM A351 Gr. CF8M / 1.4408	-50 °C to +260 °C	6
		350-800	Nodular cast iron ASTM A536 Gr. 60-40-18 (body type T1 only)	-10 °C to +100 °C	3g
		350-600	High-strength stainless steel ASTM A351 Gr. CK3MCUN (254SMO)	-29 °C to +100 °C	7d
		350-450	Stainless steel ASTM A351 Gr. CF3M / 1.4409	-50 °C to +260 °C	6t
		350-450	Stainless steel ASTM A351 Gr. CF3M Mo > 2,75 %	-50 °C to +260 °C	6m
210	Shaft	350-1200	Stainless steel ASTM A564 Gr. 630 / 1.4542 (17.4 PH)	-50 °C to +260 °C	6e
		350-1200	Stainless steel AISI 431 / 1.4057	-10 °C to +260 °C	6h
		350-450	Stainless steel 1.4462 (0 bar < operating pressure <= 16 bar)	-50 °C to +260 °C	7e
		500-1200	Stainless steel ASTM A479 Gr. 316L (0 bar < operating pressure <= 10 bar)	-50 °C to +260 °C	6
		350-600	Stainless steel 1.4547	-29 °C to +260 °C	7d
213	Actuating shaft	50-1200	Stainless steel ASTM A564 Gr. 630 / 1.4542 (17-4 PH)	-50 °C to +260 °C	6e
		50-1200	Stainless steel AISI 431 / 1.4057	-50 °C to +260 °C	6h
		50-450	Stainless steel 1.4462 (0 bar < operating pressure <= 16 bar)	-50 °C to +260 °C	7e
		500-1200	Stainless steel ASTM A479 Gr. 316L (0 bar < operating pressure <= 10 bar)	-50 °C to +260 °C	6
		50-600	Stainless steel 1.4547	-50 °C to +260 °C	7d
310.1 <sup>8)</sup>	Upper plain bearing	50-1200	Stainless steel with reinforced PTFE coating		
310.2 <sup>8)</sup>	Lower plain bearing	50-1200	Stainless steel with reinforced PTFE coating		
314 <sup>8)</sup>	Anti-friction disc	350-1200	Stainless steel		
543 <sup>8)</sup>	Spacer bush	350-1200	Stainless steel		
553 <sup>8)</sup>	Upper thrust insert	50-300	Stainless steel, hardened		
	Thrust insert, two-piece	350-1200	Stainless steel		
560.1 <sup>8)</sup>	Pin	50-600	Stainless steel		
560.2 <sup>8)</sup>					

8460.11/14-EN

<sup>8</sup> Guiding elements spare parts kit

Part No.	Description	DN	Materials	Temperature	KSB code
68-4 <sup>8)9)</sup>	Foil	50-300	Stainless steel		
901.2	Hexagon head bolt	350-1200	Stainless steel		
940 <sup>8)</sup>	Key	650-1200	Stainless steel		
970	Name plate	50-1200	Stainless steel		

**Table 13:** List of components: bracket and gland follower / DN 50 - 1200

Part No.	Description	DN	Materials	Temperature	KSB code
143/194	Lantern/bracket	50-1200	Steel, sherardised and chromated		
196	Locking plate	650-1200	Stainless steel 1.4404		
452	Gland follower	50-1200	Stainless steel		
554	Washer, flat	50-1200	Stainless steel		
901.1	Hexagon head bolt	50-1200	Stainless steel A4-70		
902	Stud	50-1200	Stainless steel A4-70		
920	Hexagon nut	50-1200	Stainless steel A4-70		

**Table 14:** List of components: extension (optional)

Part No.	Description	DN	Materials	Temperature	KSB code
13.21	Extension	50-600	Stainless steel		
		80-800	Nodular cast iron		
310.3 <sup>8)9)</sup>	Lower plain bearing	350-600	Stainless steel + PTFE		
412.1 <sup>8)9)</sup>	O-ring	50-600	Viton (FKM)		
412.2 <sup>8)9)</sup>	O-ring	50-600	Viton (FKM)		
412.3 <sup>8)9)</sup>	O-ring	50-600	Viton (FKM)		
901.1	Hexagon head bolt	50-600	Stainless steel A4-70		

---

<sup>9</sup> Part from shaft seal spare parts kit



Detail views of all seat types

Table 15: Plastomer seat

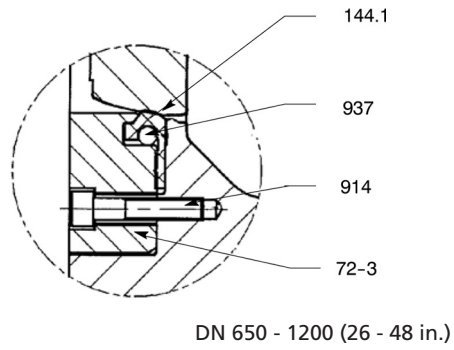
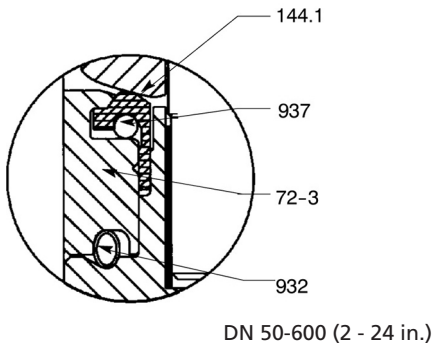

Table 16: Fire-safe plastomer seat

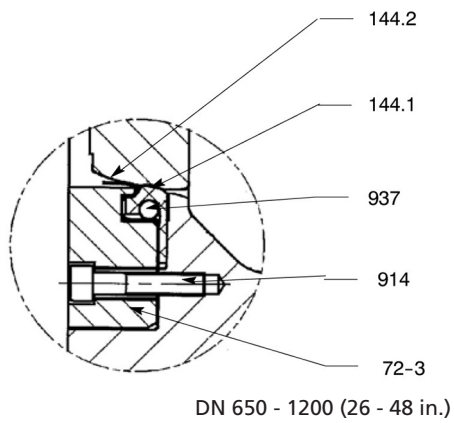
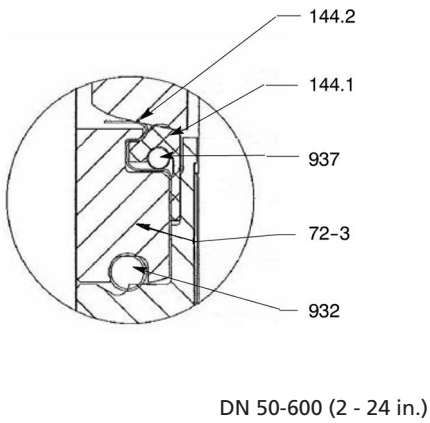

Table 17: Elastomer seat

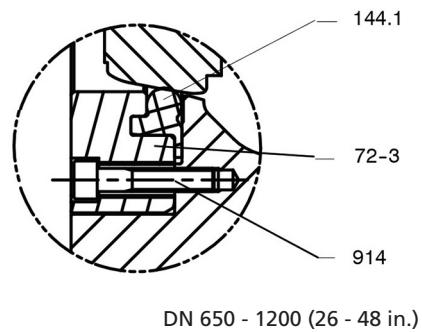
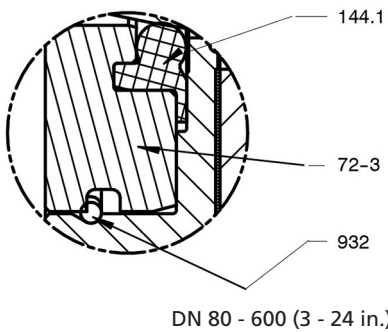
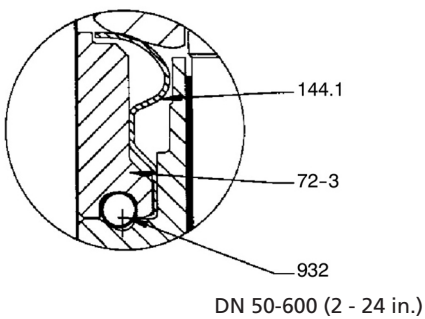

Table 18: Metal seat



**Table 19:** List of components: models with plastomer seat / DN 50 - 1200

Part No.	Description	Materials	Temperature	KSB code
01-48 <sup>10)11)</sup>	Gland packing	Pure PTFE	-10 °C to +220 °C	
		Graphite, expanded	-50 °C to +260 °C	
		Graphite compliant with emissions control requirements	-50 °C to +260 °C	
144.1 <sup>12)</sup>	Plastomer seat	PTFE, glass fibre reinforced	-10 °C to +220 °C	FB
		Pure PTFE	-50 °C to +150 °C	FC
41-2 <sup>10)11)</sup>	Static sealing element	Pure PTFE / optional: expanded graphite		
72-3	Retaining flange	Stainless steel		
550	Valve disc	Stainless steel	-50 °C to +260 °C	6
		ASTM A351 Gr. CF8M / 1.4408		
		Stainless steel	-50 °C to +260 °C	6t
		ASTM A351 Gr. CF3M / 1.4409		
		Stainless steel	-50 °C to +260 °C	6m
		ASTM A 351 Gr. CF3M Mo > 2,75 % High-strength stainless steel ASTM A351 Gr. CK3MCuN (254SMO)	-50 °C to +260 °C	7d
932 <sup>12)</sup>	Upper circlip	Stainless steel		
937 <sup>12)</sup>	Retaining wire	Stainless steel		

**Table 20:** List of components: models with fire-safe plastomer seat / DN 50 - 1200

Part No.	Description	Materials	Temperature	KSB code
01-48 <sup>10)11)</sup>	Gland packing	Graphite, expanded	-50 °C to +260 °C	
		Graphite compliant with emissions control requirements	-50 °C to +260 °C	
144.1 <sup>12)</sup>	Plastomer seat	PTFE, glass fibre reinforced	-10 °C to +220 °C	FF
144.2 <sup>12)</sup>	Fire-safe metal seat	Stainless steel ASTM A240 Gr. 316L / 1.4404		
144.1 <sup>12)</sup>	Plastomer seat	Pure PTFE	-50 °C to +150 °C	FI
144.2 <sup>12)</sup>	Fire-safe metal seat	Stainless steel ASTM A240 Gr. 316L / 1.4404		
41-2 <sup>10)11)</sup>	Static sealing element	Graphite, expanded		
550	Valve disc	Stainless steel	-50 °C to +260 °C	6
		ASTM A351 Gr. CF8M / 1.4408		
		Hard chrome plated		
		Stainless steel	-50 °C to +260 °C	6t
		ASTM A351 Gr. CF 3M / 1.4409		
		Hard chrome plated		
		Stainless steel	-50 °C to +260 °C	6m
		ASTM A 351 Gr. CF3M Mo > 2,75 % Hard chrome plated High-strength stainless steel ASTM A351 Gr. CK3MCuN (254SMO) Hard chrome plated	-50 °C to +260 °C	7d
72-3	Retaining flange	Stainless steel		
932 <sup>12)</sup>	Upper circlip	Stainless steel		
937 <sup>12)</sup>	Retaining wire	Stainless steel		

<sup>10</sup> Guiding elements spare parts kit

<sup>11</sup> Part from shaft seal spare parts kit

<sup>12</sup> Seat ring spare parts kit

**Table 21:** List of components, model with elastomer seat / DN 50 - 1200

Part No.	Description	Materials	Temperature	KSB code
01-48 <sup>10)11)</sup>	Gland packing	Pure PTFE	-10 °C to +220 °C	
144.1 <sup>12)</sup>	Elastomer seat	VITON (FKM) ( $\Delta P = 16$ bar max.)	-5 °C to +100 °C	VD
		Nitrile (NBR) ( $\Delta P = 16$ bar max.)	-10 °C to +100 °C	KD
41-2 <sup>10)11)</sup>	Static sealing element	Pure PTFE	-50 °C to +260 °C	
72-3	Retaining flange	Carbon steel	-29 °C to +260 °C	
550	Valve disc	Stainless steel ASTM A351 Gr. CF8M / 1.4408	-50 °C to +260 °C	6
		Stainless steel ASTM A351 Gr. CF3M / 1.4409 Available up to DN 450 (18 in.)	-50 °C to +260 °C	6t
		Stainless steel ASTM A351 Gr. CF3M Mo > 2,75 % Available up to DN 450 (18 in.)	-50 °C to +260 °C	6m
		High-strength stainless steel ASTM A351 Gr. CK3MCuN (2545MO)	-50 °C to +260 °C	7d
		Aluminium bronze ASTM B148 Gr. C95400 Available up to DN 800 (32 in.)	-29 °C to +260 °C	2a
932 <sup>12)</sup>	Upper circlip	Stainless steel		

**Table 22:** List of components: models with metal seat / DN 50 - 600

Part No.	Description	Materials	Temperature	KSB code
01-48 <sup>10)11)</sup>	Gland packing	Graphite, expanded	-50 °C to +260 °C	
		Pure PTFE	-10 °C to +220 °C	
		Graphite compliant with emissions control requirements	-50 °C to +260 °C	
144.1 <sup>12)</sup>	Metal seat	Stainless steel 301 / 1.4310	-50 °C to +260 °C	6a
41-2 <sup>10)11)</sup>	Static sealing element	Graphite, expanded / optional: pure PTFE		
550	Valve disc	Stainless steel ASTM A351 Gr. CF8M / 1.4408	-50 °C to +260 °C	6
		Hard chrome plated		
72-3	Retaining flange	Stainless steel		
932 <sup>12)</sup>	Upper circlip	Stainless steel		

Variants

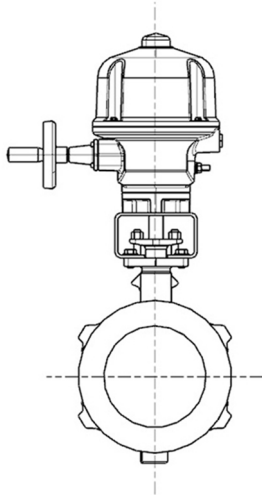

Electric actuator

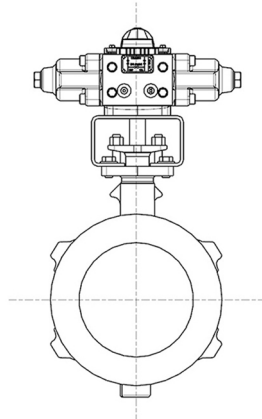

HQ hydraulic actuator

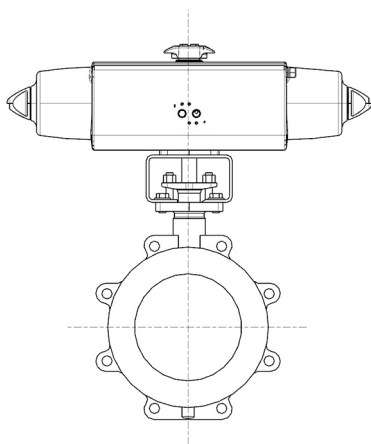

ACTAIR NG pneumatic actuator

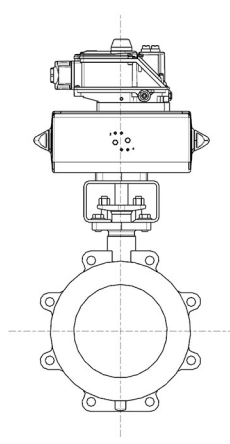

ACTAIR NG + AMTRONIC  
ACTAIR NG + Positionneur  
SMARTRONIC

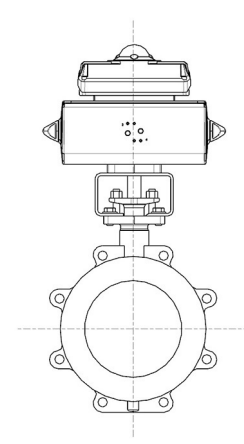

ACTAIR NG +  
AMTROBOX, AMTROBOX S, AMTROBOX R,  
AMTROBOX EEx-ed, AMTROBOX EEx-ia

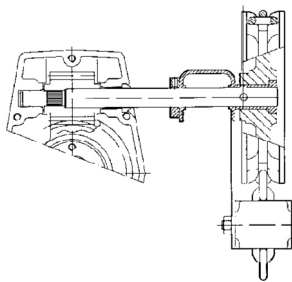

Chain wheel

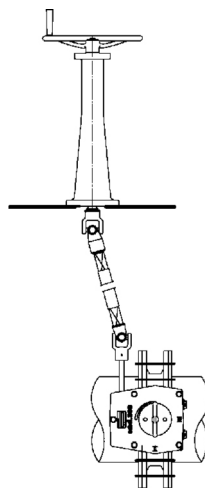

Deck stand

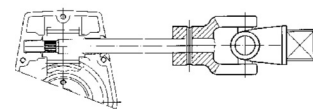

Cardan connection

Dimensions

Dimensions of DANAIS 150 with wafer-type body with flat faces - T1

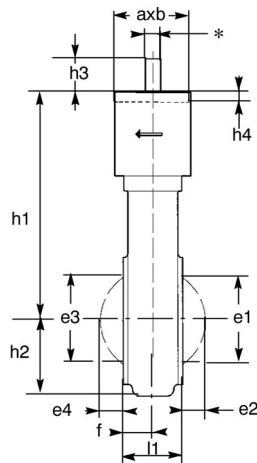

DANAIS 150 T1

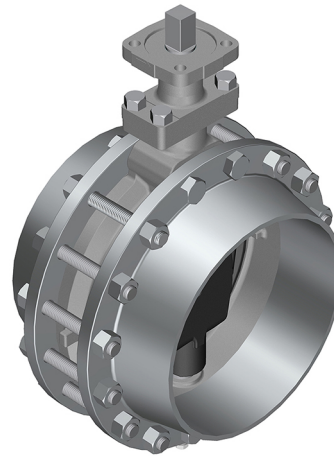

3D drawing of DANAIS 150 T1 (with extension option)

\* Flat end in  $\varnothing z$  or  $\varnothing s$

Table 23: Dimensions [mm]

DN	NPS [inch]	l1	h1 <sup>13)</sup>	h2	f	Top flange to ISO 5211		a	b	Square shaft end		Flat shaft end			Valve disc open			
						No.	h4			$\varnothing s$	h3	$\varnothing s$	$\varnothing z$	h3	e1	e2	e3	e4
50	2	43	165	53	21,5	F05	5	55	105	-	-	11	14	24	23	0	33	4
65	2½	46	175	60	23,0	F05	5	55	105	-	-	11	14	24	41	6	48	9
80	3	46	185	68	24,0	F05	5	55	105	-	-	11	14	24	59	13	61	15
100	4	54	200	82	27,0	F05	5	55	105	-	-	14	18	24	78	18	81	21
125	5	57	225	92	28,5	F07	5	73	125	-	-	14	18	30	99	27	103	30
150	6	57	240	117	28,5	F07	5	73	125	-	-	17	22	32	127	39	131	43
200	8	62	290	153	34,5	F10	5	95	145	-	-	19	25	35	177	62	175	59
250	10	70	335	182	38,0	F12	5	120	190	25	45	-	-	-	225	82	230	80
300	12	80	365	230	42,0	F12	5	120	190	27	45	-	-	-	265	96	266	98
350	14	92	435	307	47,5	F14	5	135	210	30	55	-	-	-	308	112	311	116
400	16	102	465	332	56,5	F14	5	135	210	36	55	-	-	-	359	133	358	132
450	18	114	530	371	61,0	F16	8	160	250	40	65	-	-	-	418	155	418	160
500	20	127	560	398	65,5	F16	8	160	250	40	65	-	-	-	455	167	455	175
550	22	154	634	422	73	F25	8	275	320	50	65	-	-	-	495	189	489	179
600	24	154	660	455	77,0	F25	8	275	320	50	65	-	-	-	546	201	546	211
650	26	165	720	511	82,5	F25	8	300	320	55	80	-	-	-	585	222	606	232
700	28	165	750	537	82,5	F25	8	300	320	60	80	-	-	-	619	238	640	248
750	30	190	780	569	95,0	F25	8	300	320	60	80	-	-	-	663	250	688	262
800	32	190	810	599	95,0	F25	8	300	320	70	110	-	-	-	715	275	740	287
900	36	203	930	657	101,5	F30	10	320	400	70	110	-	-	-	821	322	845	333
1000	40	216	1000	730	108,0	F30	10	320	400	80	111	-	-	-	914	362	942	376
1200	48	254	1170	860	127,0	F35	12	380	500	90	110	-	-	-	1070	423	1103	439

<sup>13</sup> h1 is identical for the standard design with bracket and for the extension option.

Dimensions of DANAIS 150 with full-lug body – T4

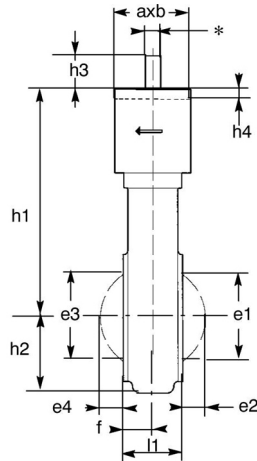

DANAIS 150 T4

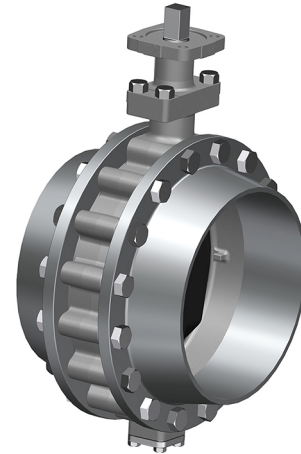

3D drawing of DANAIS 150 T4 (with extension option)

\* Flat end in  $\varnothing z$  or  $\varnothing s$

Table 24: Dimensions [mm]

DN	NPS [inch]	l1	h1	h2	f	Top flange to ISO 5211		a	b	Square shaft end		Flat shaft end			Valve disc open			
						No.	h4			$\varnothing s$	h3	$\varnothing s$	$\varnothing z$	h3	e1	e2	e3	e4
50	2	43	165	60	21,5	F05	5	55	105	-	-	11	14	24	23	0	33	4
65 <sup>14)</sup>	2½	46	175	67	23,0	F05	5	55	105	-	-	11	14	24	41	6	48	9
65 <sup>15)</sup>	2½	46	175	82	23,0	F05	5	55	105	-	-	11	14	24	41	6	48	9
80 <sup>16)</sup>	3	46	185	70	24,0	F05	5	55	105	-	-	11	14	24	59	13	61	15
80 <sup>17)</sup>	3	46	185	89	24,0	F05	5	55	105	-	-	11	14	24	59	13	61	15
100	4	54	200	104	27,0	F05	5	55	105	-	-	14	18	24	78	18	81	21
125	5	57	225	121	28,5	F07	5	73	125	-	-	14	18	30	99	27	103	30
150	6	57	240	135	28,5	F07	5	73	125	-	-	17	22	32	127	39	131	43
200 <sup>18)</sup>	8	62	290	157	34,5	F10	5	95	145	-	-	19	25	35	177	62	175	59
200 <sup>19)</sup>	8	62	290	169	34,5	F10	5	95	145	-	-	19	25	35	177	62	175	59
250	10	70	335	205	38,0	F12	5	120	190	25	45	-	-	-	225	82	230	80
300 <sup>20)</sup>	12	80	365	230	42,0	F12	5	120	190	27	45	-	-	-	265	96	266	98
300 <sup>21)</sup>	12	80	365	235	42,0	F12	5	120	190	27	45	-	-	-	265	96	266	98
350	14	92	435	307	47,5	F14	5	135	210	30	55	-	-	-	308	112	311	116
400	16	102	465	332	56,5	F14	5	135	210	36	55	-	-	-	359	133	358	132
450	18	114	530	371	61,0	F16	8	160	250	40	65	-	-	-	418	155	418	160
500	20	127	560	398	65,5	F16	8	160	250	40	65	-	-	-	455	167	455	175
550	22	154	634	422	73,0	F25	8	275	320	50	65	-	-	-	495	189	489	179
600	24	154	660	455	77,0	F25	8	275	320	50	65	-	-	-	546	201	546	211
650	26	165	720	511	82,5	F25	8	300	320	55	80	-	-	-	585	222	606	232
700	28	165	750	537	82,5	F25	8	300	320	60	80	-	-	-	619	238	640	248
750	30	190	780	569	95,0	F25	8	300	320	60	80	-	-	-	663	250	688	262
800	32	190	810	599	95,0	F25	8	300	320	70	110	-	-	-	715	275	740	287
900	36	203	930	657	101,5	F30	10	320	400	70	110	-	-	-	821	322	845	333
1000	40	216	1000	730	108,0	F30	10	320	400	80	111	-	-	-	914	362	942	376
1200	48	254	1170	860	127,0	F35	12	380	500	90	110	-	-	-	1070	423	1103	439

14 Installed between flanges EN 1092-1 PN 10 and PN 16 - 4 holes, ASME B16.5 Class 150 and JIS B2220 10K  
 15 Installed between flanges EN 1092-1 PN 10 and PN 16 - 8 holes, PN 25 and JIS B2220 16K  
 16 Installed between flanges ISO 7005-1 PN 20 and ASME B16.5 Class 150  
 17 Installed between flanges EN 1092-1 PN 10, 16 and JIS B2220 10K, 16K  
 18 Installed between flanges EN 1092-1 PN 10 and ASME B16.5 Class 150  
 19 Installed between flanges EN 1092-1 PN 16, 25 and JIS B2220 10K, 16K  
 20 Installed between flanges EN 1092-1 PN 10, 16 and ASME B16.5 Class 150  
 21 Installed between flanges EN 1092-1 PN 25 and JIS B2220 10K, 16K

### Line connections

The valves can be installed between flanges in accordance with the following standards:

- EN 1092-1 PN 10, PN 16 and PN 25
- ISO 2084 PN 10, PN 16 and PN 25
- ISO 7005-1 PN 20
- ASME B16.5 Class 150
- ASME B16.47 Class 150 Series A
- JIS B2220 5K, 10K and 16K
- JIS 2238 16K

Other connection options on request.

Table 25: Wafer-type body with flat faces – T1

DN	NPS [inch]	EN 1092			ISO 7005-1	ASME		JIS B2220		
		PN 10	PN 16	PN 25	PN 20	B16.5 Class 150	B16.47 Class 150 Series A	5k	10K	16K <sup>22)</sup>
50	2	✓	✓	✓	✓	✓	•	☒	✓	☒
65	2½	✓	✓	✓	✓	✓	•	☒	✓	✓
80	3	✓	✓	✓	✓	✓	•	✓	✓	✓
100	4	✓	✓	✓	✓	✓	•	✓	✓	✓
125	5	✓	✓	✓	✓	✓	•	✓	✓	✓
150	6	✓	✓	✓	✓	✓	•	✓	✓	✓
200	8	✓	✓	✓	✓	✓	•	✓	✓	✓
250	10	✓	✓	✓	✓	✓	•	✓	✓	✓
300	12	✓	✓	✓	✓	✓	•	✓	✓	✓
350	14	✓	✓	✓	✓	✓	•	✓	✓	✓
400	16	✓	✓	✓	✓	✓	•	✓	✓	✓
450	18	✓	✓	✓	✓	✓	•	✓	✓	✓
500	20	✓	✓	✓	✓	✓	•	✓	✓	✓
550	22	✓ <sup>23)</sup>	✓ <sup>23)</sup>	•	•	•	•	✓	✓	✓
600	24	✓	✓	✓	✓	✓	•	✓	✓	✓
650	26	✓ <sup>23)</sup>	✓ <sup>23)</sup>	✓ <sup>23)</sup>	✓	•	✓	✓	✓	✓ <sup>22)</sup>
700	28	✓	✓	✓	✓	•	✓	✓	✓	✓ <sup>22)</sup>
750	30	✓ <sup>23)</sup>	✓ <sup>23)</sup>	✓ <sup>23)</sup>	✓	•	✓	✓	✓	✓ <sup>22)</sup>
800	32	✓	✓	✓	✓	•	✓	✓	✓	✓ <sup>22)</sup>
900	36	✓	✓	✓	✓	•	✓	☒	✓	✓ <sup>22)</sup>
1000	40	✓	✓	✓	✓	•	✓	☒	✓	✓ <sup>22)</sup>
1200	48	✓	✓	✓	✓	•	✓	☒	✓	✓ <sup>22)</sup>

Table 26: Symbols key

Symbol	Description	Symbol	Description
✓	Installation possible	•	Non-standardised connection
☒	Contact KSB.		

<sup>22</sup> To JIS B2238

<sup>23</sup> Nach ISO 2084

Table 27: Full-lug body – T4

DN	NPS	EN 1092			ISO 7005-1	ASME		JIS B2220		
	[inch]	PN 10	PN 16	PN 25	PN 20	B16.5 Class 150	B16.47 Class 150 Series A	5k	10K	16K <sup>22)</sup>
50	2	✓	✓	✓	✓	✓	•	☒	✓	☒
65	2½	✓	✓	✓	✓	✓	•	☒	✓	✓
80	3	✓	✓	✓	✓	✓	•	✓	✓	✓
100	4	✓	✓	✓	✓	✓	•	✓	✓	✓
125	5	✓	✓	✓	✓	✓	•	✓	✓	✓
150	6	✓	✓	✓	✓	✓	•	✓	✓	☒
200	8	✓	✓	✓	✓	✓	•	✓	✓	✓
250	10	✓	✓	✓	✓	✓	•	✓	✓	✓
300	12	✓	✓	✓	✓	✓	•	✓	✓	✓
350	14	✓	✓	✓	✓	✓	•	✓	✓	✓
400	16	✓	✓	✓	✓	✓	•	✓	✓	✓
450	18	✓	✓	✓	✓	✓	•	✓	✓	✓
500	20	✓	✓	✓	✓	✓	•	✓	✓	✓
550	22	✓ <sup>23)</sup>	✓ <sup>23)</sup>	•	•	•	•	✓	✓	✓
600	24	✓	✓	✓	✓	✓	•	✓	☒	☒
650	26	✓ <sup>23)</sup>	✓ <sup>23)</sup>	✓ <sup>23)</sup>	✓	•	✓	✓	✓	✓ <sup>22)</sup>
700	28	✓	✓	☒	✓	•	✓	✓	✓	☒
750	30	✓ <sup>23)</sup>	✓ <sup>23)</sup>	☒	✓	•	✓	✓	✓	☒
800	32	✓	✓	☒	✓	•	✓	✓	✓	☒
900	36	✓	✓	☒	✓	•	✓	☒	✓	☒
1000	40	✓	✓	☒	✓	•	✓	☒	✓	☒
1200	48	✓	✓	☒	✓	•	✓	☒	✓	☒

Table 28: Symbols key

Symbol	Description	Symbol	Description
✓	Installation possible	•	Non-standardised connection
☒	Contact KSB.		



## Installation information

### Dead-end service and downstream dismantling

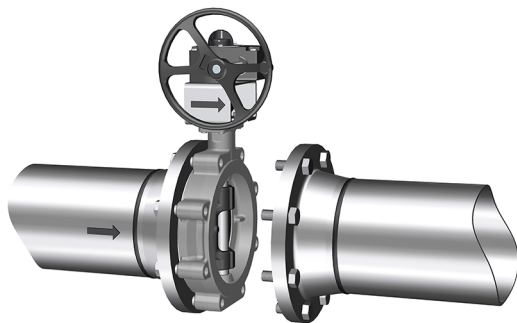

Downstream dismantling

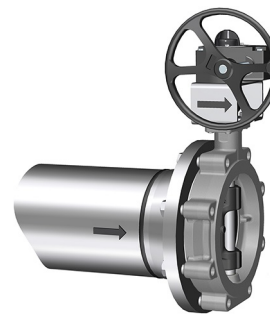

Dead-end service

Use of standard valves for dead-end service or downstream dismantling at ambient temperature:

- T1 (wafer-type body): dead-end service or downstream dismantling not permitted
- T4 (full-lug body): dead-end service or downstream dismantling permitted

Table 29: Use of DANAIS 150 in the following fluids

DANAIS 150	Gases or liquids <sup>24)</sup>		Liquids	
	Hazardous (Group 1)	Non-hazardous Group 2	Hazardous (Group 1)	Non-hazardous Group 2
Class 150 <sup>25)</sup>	All DN:	All DN:	All DN:	All DN:
PN 25 <sup>25)</sup>	Not permitted	$\Delta PS = 15 \text{ bar max.}$	$\Delta PS = 15 \text{ bar max.}$	$\Delta PS = 15 \text{ bar max.}$

$\Delta PS$ : Differential pressure

N.B.: A valve installed with a counterflange at the end of a pipeline is not a dead-end valve.

<sup>24</sup> Liquids whose vapour pressure at the max. permissible temperature is at least 0.5 bar higher than atmospheric pressure (1013 mbar)

<sup>25</sup> If the shaft is made of AISI 316L,  $\Delta PS$  is limited to 10 bar max.

Definition of sealing element

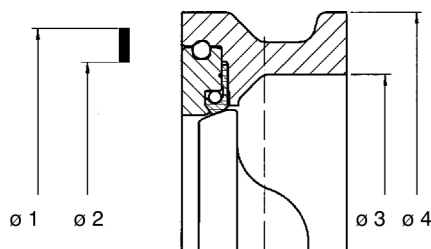

Wafer-type body with flat faces – T1

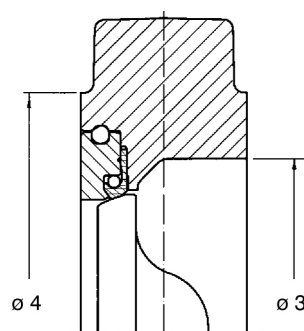

Full-lug body – T4

DN	NPS	Sealing element					Connections	
		Minimum		Maximum			T1	T4
		Max. inside diameter	Min. outside diameter	Min. inside diameter	Min. outside diameter			
[inch]	Ø 2	Ø 1	Ø 3	Ø 4 - T1	Ø 4 - T4			
50	2	69,6	84,6	62,0	90,5	91,0	PN 10/16/20/25 - ASME B16.5 Class 150 - JIS 10K	
65	2½	83,6	98,6	75,0	108,0	104,0	PN 10/16/20 - ASME B16.5 Class 150 - JIS 10K	
						117,0	PN 25 - JIS 16K	
80	3	101,2	116,6	91,0	125,0	126,0	PN 20 - ASME B16.5 Class 150 - JIS 5K	
						131,0	PN 10/16/25 - JIS 10K/16K	
100	4	126,6	142,6	117,0	154,0	156,5	PN 10/16/20/25 - ASME B16.5 Class 150 - JIS 5K/10K/16K	
125	5	153,6	169,6	144,0	183,0	185,0	PN 10/16/20/25 - ASME B16.5 Class 150 - JIS 5K/10K/16K	
150	6	180,6	199,1	171,0	214,0	215,0	PN 10/16/20/25 - ASME B16.5 Class 150 - JIS 5K/10K/16K	PN 10/16/20/25 - ASME B16.5 Class 150 - JIS 5K/10K
200	8	231,5	253,5	222,0	267,0	269,0	PN 10/20 - ASME B16.5 Class 150 - JIS 5K	
						265,0	PN 16/25 - JIS 10K/16K	
250	10	286,9	305,5	275,0	321,5	323,0	PN 10/16/20/25 - ASME B16.5 Class 150 - JIS 5K/10K/16K	
300	12	339,3	358,5	327,0	377,0	380,0	PN 10/16/20 - ASME B16.5 Class 150 - JIS 5K	
						388,0	PN 25 - JIS 10K/16K	
350	14	374,6	400,0	359,0	411,5	412,0	PN 20 - ASME B16.5 Class 150 - JIS 5K	
						428,0	PN 10/16/25 - JIS 10K/16K	
400	16	425,9	452,0	410,0	467,5	469,0	PN 10/16/20/25 - ASME B16.5 Class 150 - JIS 5K/10K/16K	
450	18	478,5	510,0	461,0	530,5	532,5	PN 10/16/20/25 - ASME B16.5 Class 150 - JIS 5K/10K/16K	
500	20	528,0	562,0	512,0	581,5	583,5	PN 10/16/20/25 - ASME B16.5 Class 150 - JIS 5K/10K/16K	
550	22	584	620	556	635	635	PN 10/16 - JIS 5K/10K/16K	
600	24	635,0	671,0	614,0	689,5	691,5	PN 10/16/20/25 - ASME B16.5 Class 150 - JIS 5K/10K/16K	PN 10/16/20/25 - ASME B16.5 Class 150 - JIS 5K
650	26	673,0	705,0	654,0	740,0	747,0	PN 10/16/20/25 - ASME B16.47 Class 150 Series A - JIS 5K/10K/16K	
700	28	722,0	756,0	704,0	794,0	794,0	PN 10/16/20/25 - ASME B16.47 Class 150 Series A - JIS 5K/10K/16K	
						798,0	PN 20 - ASME B16.47 Class 150 Series A	
750	30	774,0	807,0	754,0	855	853,5	PN 10/16/20/25 - ASME B16.47 Class 150 Series A - JIS 5K/10K/16K	
						855,0	PN 20 - ASME B16.47 Class 150 Series A	
800	32	830,0	864,0	804,0	899,0	899,0	PN 10/16/20/25 - ASME B16.47 Class 150 Series A - JIS 5K/10K/16K	
						912,0	PN 10/16	
900	36	930,0	964,0	904,0	999,0	999,0	PN 10/16/20/25 - ASME B16.47 Class 150 Series A - JIS 10K/16K	
						1020,0	PN 20 - ASME B16.47 Class 150 Series A	
1000	40	1030,0	1074,0	1004,0	1114,0	1114,0	PN 10/16/20/25 - ASME B16.47 Class 150 Series A - JIS 10K/16K	
						1122,0	PN 20 - ASME B16.47 Class 150 Series A	

8460.11/14-EN

DN	NPS	Sealing element					Connections	
		Minimum		Maximum			T1	T4
		Max. inside diameter	Min. outside diameter	Min. inside diameter	Min. outside diameter			
[inch]	Ø 2	Ø 1	Ø 3	Ø 4 - T1	Ø 4 - T4			
1200	48	1232,0	1280,0	1205,0	1329,0	1329,0	PN 10/16/20/25 - ASME B16.47 Class 150 Series A - JIS 10K/16K	PN 10/16 - JIS 10K
						1357,0		PN 20 - ASME B16.47 Class 150 Series A
N.B.:		For DN ≤ 600 we recommend using spiral wound gaskets to ISO 7483 - PN 10 to 25. For DN > 600 we recommend using spiral wound gaskets to EN 1514-2.						

N.B.: The inside diameter of the gasket can be smaller than Ø 3.

## Bolting and weights

### Bolting and weights for wafer-type body with flat faces - T1

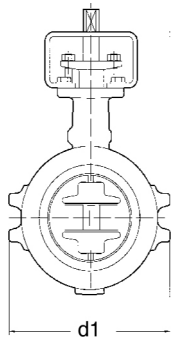

Drawing of DANAIS 150 T1

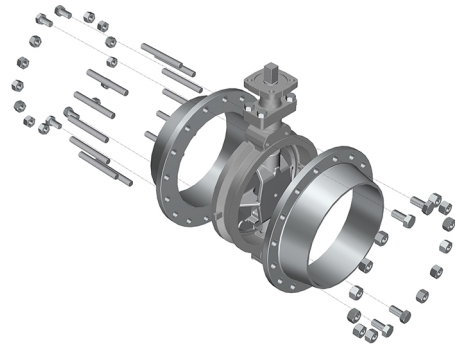

Exploded view of DANAIS 150 T1

The drawings do not indicate the exact product design (number of tapped lugs/clearance holes).

**N.B.: Bolting is not included in our standard scope of supply.**

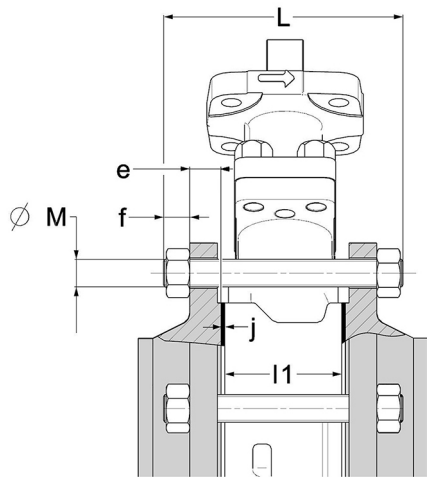

Sectional drawing of T1 body bolting with tie bolts

Length of tie bolt  
 $L = l1 + 2e + 2f + 2j$

- l1: face-to-face length of valve
- e: flange thickness (customer-specific)
- f: standardised overhang of tie bolt
- j: flange gasket thickness

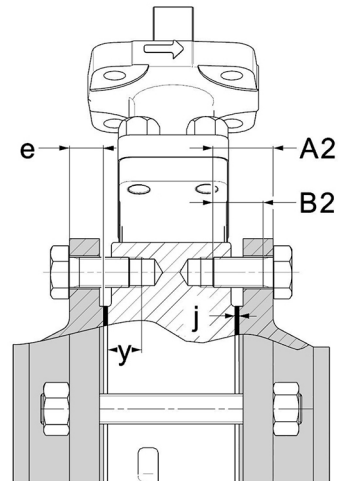

Sectional drawing of T1 body bolting with bolts

Length of bolt at shaft passage  
 $A2 \text{ max} = e + Y + j$

- e: flange thickness (customer-specific)
- Y: max. thread engagement depth
- j: flange gasket thickness
- B2: min. bolt thread length  $B2 > A2 - e$

**Table 30:** Wafer-type body with flat faces – T1 for EN 1092-1 PN 10 and PN 16

DN	NPS	l1	d1	EN 1092-1 PN 10					EN 1092-1 PN 16					[kg]
				Ø M	Tie bolt		Bolt A2		Ø M	Tie bolt		Bolt A2		
	[inch]				f	Qty	Y	Qty		f	Qty	Y	Qty	
50	2	43	104	M16	20	4	-	-	M16	20	4	-	-	3,2
65	2½	46	123	M16	20	4/8	-	-	M16	20	4/8	-	-	3,8
80	3	46	140	M16	20	8	-	-	M16	20	8	-	-	4,5
100	4	54	180	M16	20	8	-	-	M16	20	8	-	-	6,4
125	5	57	210	M16	20	8	-	-	M16	20	8	-	-	9,7
150	6	57	235	M20	24	8	-	-	M20	24	8	-	-	12,7
200	8	62	271	M20	24	8	-	-	M20	24	12	-	-	22,5
250	10	70	323	M20	24	12	-	-	M24	29	12	-	-	34,0
300	12	80	380	M20	24	12	-	-	M24	29	12	-	-	48,8
350	14	92	449	M20	24	16	-	-	M24	29	16	-	-	64,5
400	16	102	505	M24	29	16	-	-	M27	32	16	-	-	89,0
450	18	114	570	M24	29	16	32	4	M27	32	16	31	4	133,5
500	20	127	621	M24	29	16	35	4	M30	35	16	39	4	168,0
550	22	154	635	M27	32	16	42	4	M30	35	16	42	4	218,0
600	24	154	730	M27	32	16	40	4	M33	38	16	48	4	270,5
650	26	165	742	M27	32	20	39	4	M33	38	20	35	4	360,0
700	28	165	798	M27	32	20	39	4	M33	38	20	36	4	415,0
750	30	190	859	M30	35	20	47	4	M33	38	20	46	4	510,0
800	32	190	903	M30	35	20	47	4	M36	42	20	44	4	575,0
900	36	203	1003	M30	35	24	47	4	M36	42	24	43	4	725,0
1000	40	216	1118	M33	38	24	48	4	M39	45	24	46	4	930,0
1200	48	254	1333	M36	42	28	53	4	M45	52	28	48	4	1470,0

**Table 31:** Wafer-type body with flat faces – T1 for EN 1092-1 PN 25

DN	NPS	l1	d1	EN 1092-1 PN 25					[kg]
				Ø M	Tie bolt		Bolt A2		
	[inch]				f	Qty	Y	Qty	
50	2	43	104	M16	20	4	-	-	3,2
65	2½	46	123	M16	20	8	-	-	3,8
80	3	46	140	M16	20	8	-	-	4,5
100	4	54	180	M20	24	8	-	-	6,4
125	5	57	210	M24	29	8	-	-	9,7
150	6	57	235	M24	29	8	-	-	12,7
200	8	62	271	M24	29	12	-	-	22,5
250	10	70	323	M27	29	12	-	-	34,0
300	12	80	380	M27	32	16	-	-	48,8
350	14	92	449	M30	35	16	-	-	64,5
400	16	102	505	M33	38	16	-	-	89,0
450	18	114	570	M33	38	16	31	4	133,5
500	20	127	621	M33	38	16	42	4	168,0
550	22	-	-	-	-	-	-	-	-
600	24	154	730	M36	42	16	46	4	270,5
650	26	165	742	M36	42	20	34	4	360,0
700	28	165	798	M39	45	20	33	4	415,0
750	30	190	859	M39	45	20	44	4	510,0
800	32	190	903	M45	52	20	40	4	575,0
900	36	203	1003	M45	52	24	39	4	725,0
1000	40	216	1118	M52	60	24	43	4	930,0
1200	48	254	1333	M52	60	28	45	4	1470,0

**Table 32:** Wafer-type body with flat faces – T1 for EN 1092-1 PN 20, ASME B16.5 Class 150 and ASME B16.47 Class 150 Series A

DN	NPS	l1	d1	EN 1092-1 PN 20				ASME B16.5 Class 150 For DN <= 600 ASME B16.47 Class 150 Series A For DN > 600						[kg]
				Ø M	Tie bolt		Bolt A2		UN/ UNC <sup>26)</sup>	Tie bolt		Bolt A2		
	f				Qty	Y	Qty	[inch]		f	Qty	Y	Qty	
50	2	43	104	M16	20	4	-	-	5/8	20	4	-	-	3,2
65	2½	46	123	M16	20	4	-	-	5/8	20	4	-	-	3,8
80	3	46	140	M16	20	4	-	-	5/8	20	4	-	-	4,5
100	4	54	180	M16	20	8	-	-	5/8	20	8	-	-	6,4
125	5	57	210	M20	24	8	-	-	3/4	24	8	-	-	9,7
150	6	57	235	M20	24	8	-	-	3/4	24	8	-	-	12,7
200	8	62	271	M20	24	8	-	-	3/4	24	8	-	-	22,5
250	10	70	323	M24	29	12	-	-	7/8	29	12	-	-	34,0
300	12	80	380	M24	29	12	-	-	7/8	29	12	-	-	48,8
350	14	92	449	M27	32	12	-	-	1	32	12	-	-	64,5
400	16	102	505	M27	32	16	-	-	1	32	16	-	-	89,0
450	18	114	570	M30	35	12	40	4	1 1/8	35	12	40	4	133,5
500	20	127	621	M30	35	16	39	4	1 1/8	35	16	39	4	168,0
550	22	-	-	-	-	-	-	-	-	-	-	-	-	-
600	24	154	730	M33	38	16	48	4	1 1/4	38	16	48	4	270,5
650	26	165	742	M33	38	20	35	4	1 1/4	38	20	35	4	360,0
700	28	165	798	M33	38	24	30	4	1 1/4	38	24	30	4	415,0
750	30	190	859	M33	38	24	39	4	1 1/4	38	24	39	4	510,0
800	32	190	903	M39	45	24	35	4	1 1/2	45	24	35	4	575,0
900	36	203	1003	M39	45	28	37	4	1 1/2	45	28	37	4	725,0
1000	40	216	1118	M39	45	32	36	4	1 1/2	45	32	36	4	930,0
1200	48	254	1333	M39	45	40	41	4	1 1/2	45	40	41	4	1470,0

<sup>26)</sup> For bolting < 1 in.: only UNC

Table 33: Wafer-type body with flat faces – T1 for JIS B2220 5K

DN	NPS	l1	d1	JIS B2220 5K					[kg]
				Ø M	Tie bolt		Bolt A2		
	[inch]				f	Qty	Y	Qty	
50	2	-	-	-	-	-	-	-	-
65	2½	-	-	-	-	-	-	-	-
80	3	46	140	M16	20	4	-	-	4,5
100	4	54	180	M16	20	8	-	-	6,4
125	5	57	210	M16	20	8	-	-	9,7
150	6	57	235	M16	20	8	-	-	12,7
200	8	62	271	M20	24	8	-	-	22,5
250	10	70	323	M20	24	12	-	-	34,0
300	12	80	380	M20	24	12	-	-	48,8
350	14	92	449	M22	26	12	-	-	64,5
400	16	102	505	M22	26	16	-	-	89,0
450	18	114	570	M22	26	12	40	4	133,5
500	20	127	621	M22	26	16	41	4	168,0
550	22	154	635	M24	29	16	42	4	218,0
600	24	154	715	M24	29	16	43	4	270,5
650	26	165	742	M24	29	20	39	4	360,0
700	28	165	798	M24	29	20	39	4	415,0
750	30	190	859	M30	35	20	47	4	510,0
800	32	190	903	M30	35	20	47	4	575,0
900	36	-	-	-	-	-	-	-	-
1000	40	-	-	-	-	-	-	-	-
1200	48	-	-	-	-	-	-	-	-

Table 34: Wafer-type body with flat faces – T1 for JIS 2220 10K and 16K

DN	NPS	l1	d1	JIS B2220 10K					JIS B2220 16K for DN ≤ 600 JIS B2238 16K for DN > 600					[kg]
				Ø M	Tie bolt		Bolt A2		Ø M	Tie bolt		Bolt A2		
	[inch]				f	Qty	Y	Qty		f	Qty	Y	Qty	
50	2	43	104	M16	20	4	-	-	M16	20	8	-	-	3,2
65	2½	46	123	M16	20	4	-	-	M16	20	8	-	-	3,8
80	3	46	140	M16	20	8	-	-	M20	24	8	-	-	4,5
100	4	54	180	M16	20	8	-	-	M20	24	8	-	-	6,4
125	5	57	210	M20	24	8	-	-	M22	26	8	-	-	9,7
150	6	57	235	M20	24	8	-	-	M22	26	12	-	-	12,7
200	8	62	271	M20	24	12	-	-	M22	26	12	-	-	22,5
250	10	70	323	M22	26	12	-	-	M24	29	12	-	-	34,0
300	12	80	380	M22	26	16	-	-	M24	29	16	-	-	48,8
350	14	92	449	M22	26	16	-	-	M30 x 3	35	16	-	-	64,5
400	16	102	505	M24	29	16	-	-	M30 x 3	35	16	-	-	89,0
450	18	114	570	M24	29	16	32	4	M30 x 3	35	16	32	4	133,5
500	20	127	621	M24	29	16	35	4	M30 x 3	35	16	42	4	168,0
550	22	154	635	M30	35	16	42	4	M36 x 3	42	16	42	4	218,0
600	24	154	730	M30	35	20	38	4	M36 x 3	42	20	41	4	270,5
650	26	165	742	M30	35	20	36	4	M36 x 3	42	20	38	4	360,0
700	28	165	798	M30	35	20	37	4	M39 x 3	45	20	37	4	415,0
750	30	190	859	M30	35	20	47	4	M39 x 3	45	20	48	4	510,0
800	32	190	903	M30	35	24	39	4	M45 x 3	52	20	46	4	575,0
900	36	203	1003	M30	35	24	47	4	M45 x 3	52	24	45	4	725,0
1000	40	216	1118	M36	42	24	46	4	M52 x 3	60	24	46	4	930,0
1200	48	254	1333	M36	42	28	53	4	M52 x 3	60	28	52	4	1470,0

Bolting and weights for full-lug body – T4

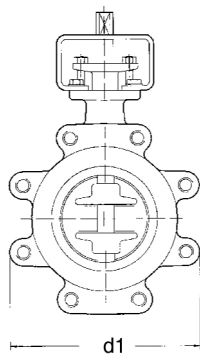

Drawing of DANAIS 150 T4

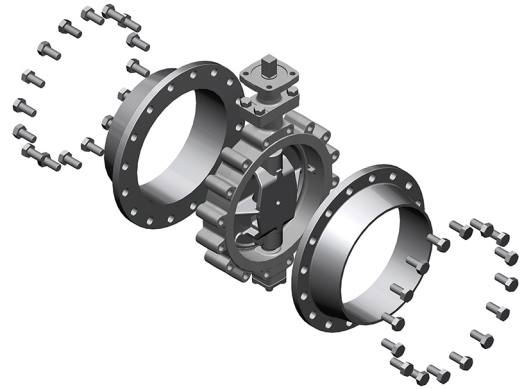

Exploded view of DANAIS 150 T4

The drawings do not indicate the exact product design  
(number of tapped lugs)

**N.B.: Bolting is not included in our standard scope of supply.**

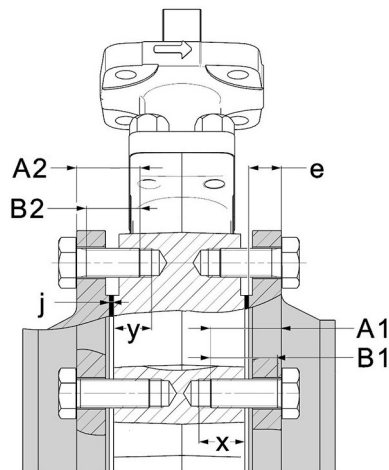

Sectional drawing of bolting, body type T4 with bolts

Bolt length

$$A1 \max = e + X + j$$

e: flange thickness (customer-specific)

X: depth of drilled hole

j: flange gasket thickness

B1: min. bolt thread length  $B1 > A1 - e$

Length of bolt at shaft passage

$$A2 \max = e + Y + j$$

e: flange thickness (customer-specific)

Y: max. thread engagement depth

j: flange gasket thickness

B2: min. bolt thread length  $B2 > A2 - e$



**Table 35: Full-lug body – T4 for EN 1092-1 PN 10 and PN 16**

DN	NPS	l1	d1	EN 1092-1 PN 10				EN 1092-1 PN 16				[kg]		
				Ø M	Bolt A1		Bolt A2		Ø M	Bolt A1			Bolt A2	
	[inch]				X	Qty	Y	Qty		X	Qty		Y	Qty
50	2	43	117	M16	20	4	-	-	M16	20	4	-	-	4,6
65	2½	46	131	M16	22	4	-	-	M16	22	4	-	-	5,2
65	2½	46	162	M16	22	8	-	-	M16	22	8	-	-	6,5
80	3	46	136	M16	22	8	-	-	M16	22	8	-	-	7,4
100	4	54	206	M16	25	8	-	-	M16	25	8	-	-	10,2
125	5	57	240	M16	25	8	-	-	M16	25	8	-	-	14,6
150	6	57	267	M20	27	8	-	-	M20	27	8	-	-	17,2
200	8	62	310	M20	30	8	-	-	-	-	-	-	-	25,5
200	8	62	338	-	-	-	-	-	M20	30	12	-	-	28,5
250	10	70	410	M20	32	12	-	-	M24	34	12	-	-	44,0
300	12	80	460	M20	32	12	-	-	M24	38	12	-	-	64,8
350	14	92	508	M20	30	16	-	-	M24	35	16	-	-	97,5
400	16	102	593	M24	34	16	-	-	M27	38	16	-	-	130,0
450	18	114	620	M24	32	16	32	4	M27	40	16	31	4	178,5
500	20	127	705	M24	35	16	35	4	M30	39	16	39	4	218,0
550	22	154	770	M27	54	16	42	4	M30	60	16	42	4	283,0
600	24	154	822	M27	40	16	40	4	M33	48	16	48	4	355,0
650	26	165	875	M27	46	20	39	4	M33	55	20	35	4	470,0
700	28	165	895	M27	46	20	39	4	M33	55	20	36	4	500,0
750	30	190	950	M30	50	20	47	4	M33	55	20	46	4	610,0
800	32	190	1010	M30	50	20	47	4	M36	59	20	44	4	680,0
900	36	203	1111	M30	50	24	47	4	M36	59	24	43	4	860,0
1000	40	216	1236	M33	55	24	48	4	M39	64	24	46	4	1140,0
1200	48	254	1470	M36	59	28	53	4	M45	73	28	48	4	1850,0

**Table 36: Full-lug body – T4 for EN 1092-1 PN 25**

DN	NPS	l1	d1	EN 1092-1 PN 25				[kg]	
				Ø M	Bolt A1		Bolt A2		
	[inch]				X	Qty	Y		Qty
50	2	43	117	M16	20	4	-	-	4,6
65	2½	46	162	M16	22	8	-	-	6,5
80	3	46	136	M16	22	8	-	-	7,4
100	4	54	206	M20	26	8	-	-	10,2
125	5	57	240	M24	27	8	-	-	14,6
150	6	57	267	M24	27	8	-	-	17,2
200	8	62	338	M24	30	12	-	-	28,5
250	10	70	410	M27	32	12	-	-	44,0
300	12	80	470	M27	39	16	-	-	68,8
350	14	92	508	M30	38	16	-	-	97,5
400	16	102	593	M33	43	16	-	-	130,0
450	18	114	620	M33	41	16	31	4	178,5
500	20	127	705	M33	42	16	42	4	218,0
550	22	-	-	-	-	-	-	-	-
600	24	154	822	M36	46	16	46	4	355,0
650	26	165	875	M36	59	20	34	4	470,0
700	28	-	-	-	-	-	-	-	-
750	30	-	-	-	-	-	-	-	-
800	32	-	-	-	-	-	-	-	-
900	36	-	-	-	-	-	-	-	-
1000	40	-	-	-	-	-	-	-	-
1200	48	-	-	-	-	-	-	-	-

**Table 37:** Full-lug body – T4 for EN 1092-1 PN 20, ASME B16.5 Class 150 and ASME B16.47 Class 150 Series A

DN	NPS	l1	d1	EN 1092-1 PN 20				ASME B16.5 Class 150 For DN <= 600 ASME B16.47 Class 150 Series A For DN > 600						[kg]
				Ø M	Bolt A1		Bolt A2		UN/ UNC <sup>27)</sup>	Bolt A1		Bolt A2		
	X				Qty	Y	Qty	[inch]		X	Qty	Y	Qty	
50	2	43	117	M16	20	4	-	-	5/8	20	4	-	-	4,6
65	2½	46	131	M16	22	4	-	-	5/8	22	4	-	-	6,5
80	3	46	136	M16	22	4	-	-	5/8	22	4	-	-	7,4
100	4	54	206	M16	25	8	-	-	5/8	25	8	-	-	10,2
125	5	57	240	M20	27	8	-	-	3/4	27	8	-	-	14,6
150	6	57	267	M20	27	8	-	-	3/4	27	8	-	-	17,2
200	8	62	310	M20	30	8	-	-	3/4	30	8	-	-	28,5
250	10	70	410	M24	34	12	-	-	7/8	34	12	-	-	44,0
300	12	80	470	M24	38	12	-	-	7/8	38	12	-	-	68,8
350	14	92	508	M27	37	12	-	-	1	37	12	-	-	97,5
400	16	102	593	M27	38	16	-	-	1	38	16	-	-	130,0
450	18	114	620	M30	40	16	-	-	1 1/8	40	16	-	-	178,5
500	20	127	705	M30	39	16	39	4	1 1/8	39	20	-	-	218,0
550	22	-	-	-	-	-	-	-	-	-	-	-	-	-
600	24	154	822	M33	48	16	48	4	1 1/4	48	20	-	-	355,0
650	26	165	875	M33	55	20	35	4	1 1/4	55	20	35	4	470,0
700	28	165	920	M33	55	24	30	4	1 1/4	55	24	30	4	530,0
750	30	190	970	M33	55	24	39	4	1 1/4	55	24	39	4	640,0
800	32	190	1045	M39	64	24	35	4	1 1/2	64	24	35	4	750,0
900	36	203	1155	M39	64	28	37	4	1 1/2	64	28	37	4	965,0
1000	40	216	1270	M39	64	32	36	4	1 1/2	64	32	36	4	1230,0
1200	48	254	1493	M39	64	40	41	4	1 1/2	64	40	41	4	1980,0

<sup>27</sup> UN thread; bolts < 1 in.: UNC thread

Table 38: Full-lug body – T4 for JIS B2220 5K

DN	NPS	l1	d1	JIS B2220 5K					[kg]
				Ø M	Bolt A1		Bolt A2		
	[inch]				X	Qty	Y	Qty	
50	2	-	-	-	-	-	-	-	-
65	2½	-	-	-	-	-	-	-	-
80	3	46	176	M16	20	4	-	-	6,0
100	4	54	206	M16	24	8	-	-	10,2
125	5	57	240	M16	27	8	-	-	14,6
150	6	57	267	M16	27	8	-	-	17,2
200	8	62	310	M20	30	8	-	-	25,5
250	10	70	410	M20	33	12	-	-	44,0
300	12	80	470	M20	33	12	-	-	64,8
350	14	92	508	M22	31	12	-	-	87,7
400	16	102	593	M22	34	16	-	-	130,0
450	18	114	620	M22	40	16	-	-	163,5
500	20	127	705	M22	48	16	38	4	218,0
550	22	154	635	M24	48	16	42	4	283,0
600	24	154	822	M24	50	16	50	4	355,0
650	26	165	875	M24	41	20	39	4	470,0
700	28	165	895	M24	46	20	39	4	500,0
750	30	190	950	M30	50	20	47	4	610,0
800	32	190	1010	M30	50	20	47	4	680,0
900	36	-	-	-	-	-	-	-	-
1000	40	-	-	-	-	-	-	-	-
1200	48	-	-	-	-	-	-	-	-

Table 39: Full-lug body – T4 for JIS B2220 10K and 16K

DN	NPS	l1	d1	JIS B2220 10K				JIS B2220 16K for DN ≤ 600				[kg]		
				Ø M	Bolt A1		Bolt A2		Ø M	Bolt A1			Bolt A2	
	[inch]				X	Qty	Y	Qty		X	Qty		Y	Qty
50	2	43	117	M16	20	4	-	-	Contact KSB.				4,6	
65	2½	46	131	M16	22	4	-	-	-	-	-	-	-	5,2
65	2½	46	162	-	-	-	-	-	M16	22	8	-	-	6,5
80	3	46	136	M16	22	8	-	-	M20	22	8	-	-	6,0
100	4	54	206	M16	25	8	-	-	M20	26	8	-	-	10,2
125	5	57	240	M20	27	8	-	-	M22	27	8	-	-	14,6
150	6	57	267	M20	27	8	-	-	Contact KSB.				17,2	
200	8	62	310	-	-	-	-	-	M22	30	12	-	-	25,5
200	8	62	338	M20	30	12	-	-	-	-	-	-	-	25,5
250	10	70	410	M22	34	12	-	-	M24	34	12	-	-	44,0
300	12	80	470	M22	35	16	-	-	M24	38	16	-	-	64,8
350	14	92	508	M22	31	16	-	-	M30 x 3	41	16	-	-	87,7
400	16	102	593	M24	34	16	-	-	M30 x 3	40	16	-	-	130,0
450	18	114	620	M24	32	16	32	4	M30 x 3	40	16	32	4	163,5
500	20	127	705	M24	35	16	35	4	M30 x 3	42	16	42	4	218,0
550	22	154	635	M30	60	16	42	4	M36 x 3	72	16	42	4	283,0
600	24	154	822	Contact KSB.				Contact KSB.				355,0		
650	26	165	875	M30	50	20	36	4	M36 x 3	59	20	38	4	470,0
700	28	165	895	M30	50	20	37	4	Contact KSB.				500,0	
750	30	190	950	M30	50	20	47	4	Contact KSB.				610,0	
800	32	190	1045	M30	50	24	39	4	Contact KSB.				750,0	
900	36	203	1111	M30	50	24	47	4	Contact KSB.				860,0	
1000	40	216	1236	M36	59	24	46	4	Contact KSB.				1140,0	
1200	48	254	1470	M36	59	28	53	4	Contact KSB.				1850,0	







**KSB S.A.S.**  
4, allée des Barbanniers • 92635 Gennevilliers Cedex (France)  
Tél. 09 69 39 29 79  
[www.ksb.fr](http://www.ksb.fr)